



Nome do produto

## Extrator interno de 2 camadas

Para extrair rolamentos interiores, anéis exteriores de rolamentos e buchas.

Artigo Nº 21-8

Série 21

EAN 4021176011726



### Características

### Métrico

### Polegada



Rolamento de esferas ISO

6012; 6212; 6312;	6012; 6212; 6312;
6412; 16012; 61812;	6412; 16012; 61812;
61912; 6013; 6213;	61912; 6013; 6213;
6313; 16013; 61913;	6313; 16013; 61913;
6014; 6214; 6314;	6014; 6214; 6314;
16014	16014



Diâmetro interno do rolamento

56 - 70 mm 2 1/4 - 2 3/4 inch



Profundidade de utilização

85 mm 3 3/8 inch



Comprimento do extrator interno

133 mm 5 1/4 inch



Número de segmentos

2 2



Peso

1.43 kg



ainda necessita de

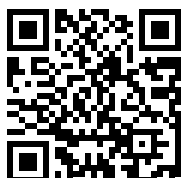

**Equipamento de martelo  
deslizante**

22-0-1



**Suportes**

22-2

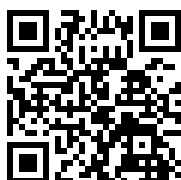

**Suportes**

22-3



é necessitado por

<b>Artigo N°</b>	<b>Nome do produto</b>
22-2	Suportes
22-3	Suportes

Faz parte de

<b>Artigo N°</b>	<b>Nome do produto</b>
24-B	Conjunto de extração e desmontagem de rolamentos de esferas
25-B	Conjunto de desmontagem de rolamentos de esferas
28-D	Conjunto de martelo deslizante e suportes de extração para extrair os rolamento de esferas e cavilhas de escarva
WT-017	Gama de extratores - Extração interna - BASIC
WT-018	Gama de extratores - Extração interna - TOP
K-22-B	Conjunto de extrator de rolamentos com suportes e martelo deslizante



é uma peça de substituição de

<b>Artigo N°</b>	<b>Nome do produto</b>
24-B	Conjunto de extração e desmontagem de rolamentos de esferas
25-B	Conjunto de desmontagem de rolamentos de esferas

Está também incluído em

<b>Artigo N°</b>	<b>Nome do produto</b>
WT-018	Gama de extratores - Extração interna - TOP

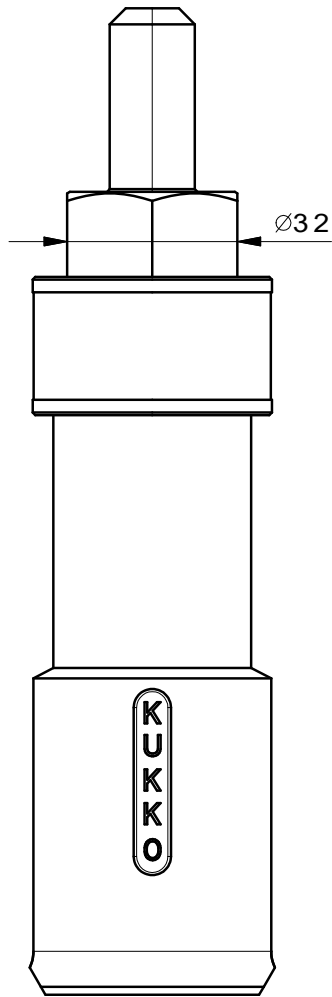
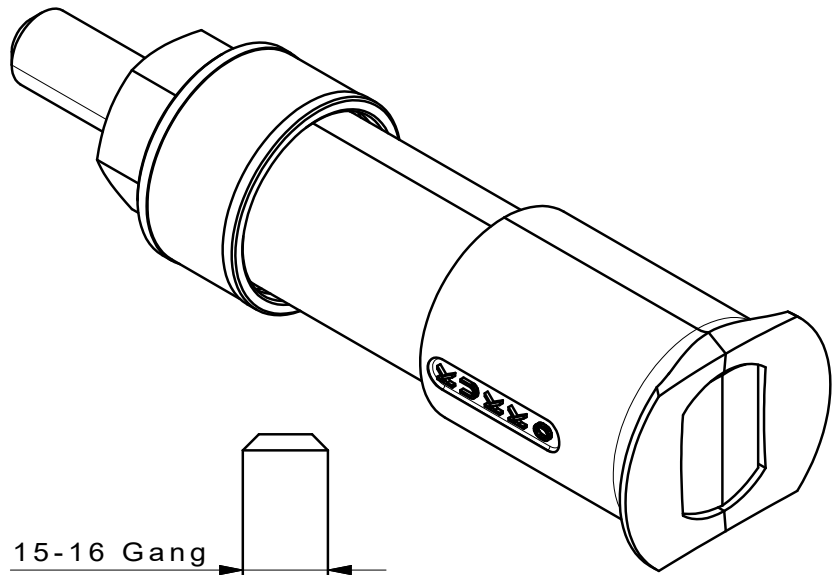
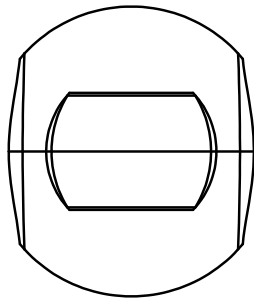

15-16 Gang

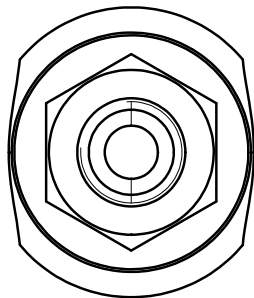
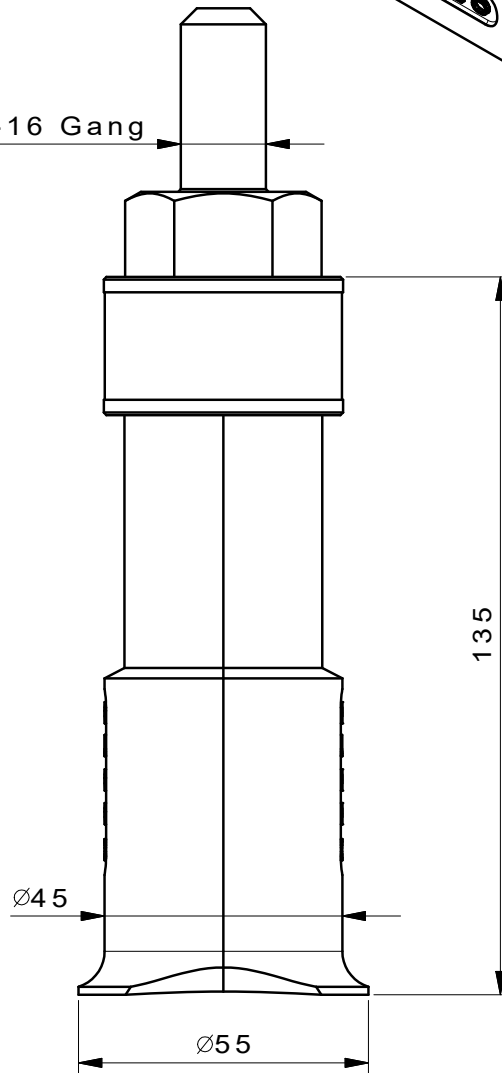

 <b>Kleinbongartz &amp; Kaiser oHG</b> Werkzeugfabrik Hilden - Germany	Dokumentname: 21-8 Innenauszieher		Toleranz: DIN ISO 2768-m
	Dokumentbeschreibung: ZSB		Material: Hochfester extra zäher Vergütungsstahl/ High tensile strength and toughness steel
Teilbeschreibung: Innenauszieher/ Internal extractor	Erstellt / Geprüft von: Schultes	Erstellungsdatum: 05/06/2015	Maßstab: 1:1
		Wärmebehandlung / Härte: vergüteter Stahl/ tempered steel	
		Oberflächenbehandlung:	
Artikelnummer / ZNR.: 21-8	Dokumentversion: -	Schutzvermerk ISO 16016 beachten	