



Product name

Extractor with self-centering jaws

For removing bearings, gears, discs, etc.

Art. No. 225-2

Series 225

EAN 4021176123412

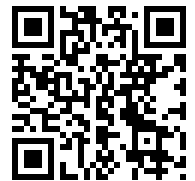

	Technical attribute	Metric	Imperial
	Spread	50 - 70 mm	2 - 2 3/4 inch
	Length of jaw	25 mm	1 inch
	Weight	1.235 kg	
	Space below	4 mm	3/16 inch
	Space next to it	14 mm	5/8 inch
	Depth	35 mm	1 3/8 inch



has to be accomplished with



Slide hammer device

22-0-1

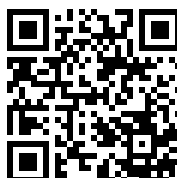

Counterstay

22-2

Technologies



AUTOGRIP

The jaws clamp and center automatically.



Part of

Art. No.

Product name

K-225-1-C

Set of 3-jaw puller with self-centering jaws

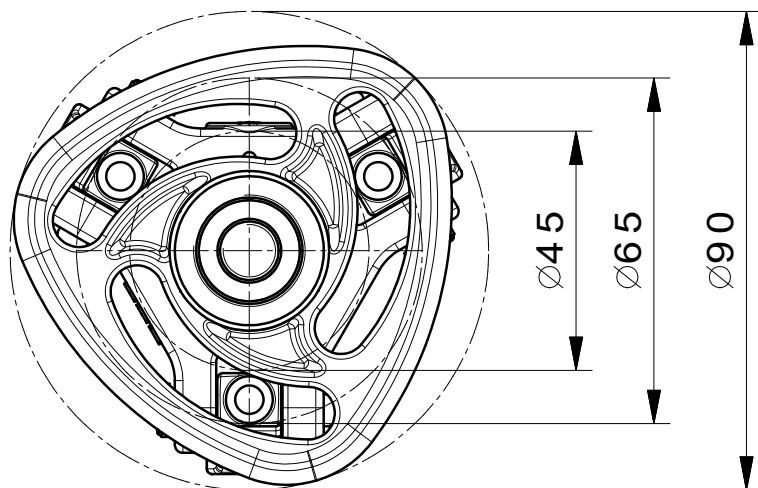
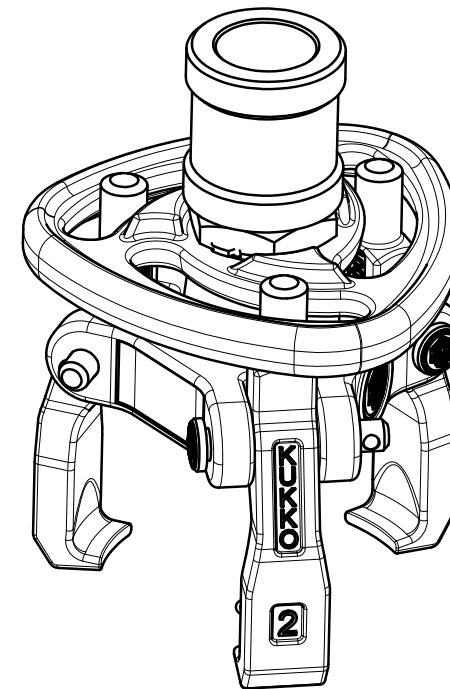
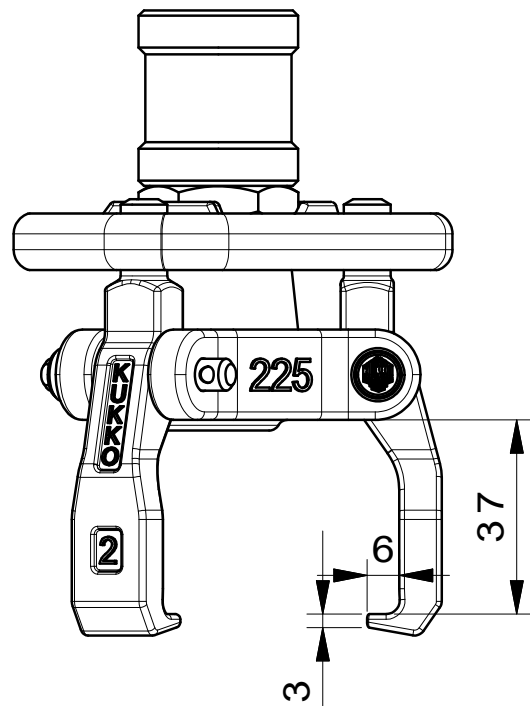
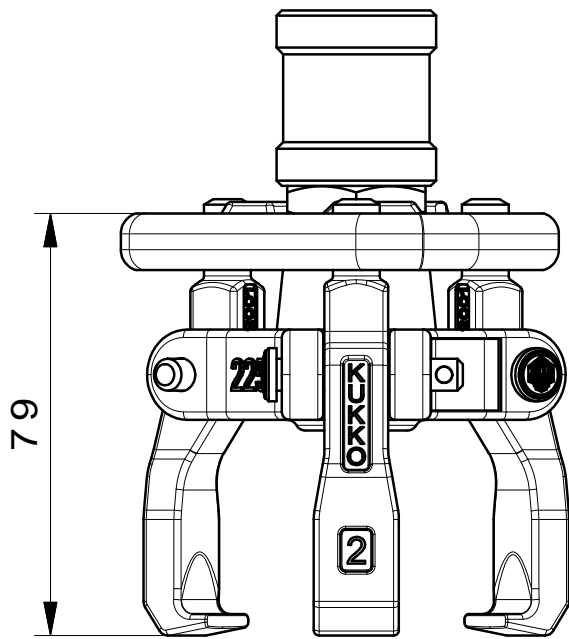

 Kleinbongartz & Kaiser oHG Werkzeugfabrik Hilden - Germany	Dokumentname: 225-2 Staub- und Fettkappenabzieher	Toleranz: DIN ISO 2768-m
	Dokumentbeschreibung: Baugruppe	Material: -
	Erstellt von: Schultes	Erstellungsdatum: 13/04/2016
Teilbeschreibung: Staub- und Fettkappenabzieher/ Extractor with self-centering jaws		Wärmebehandlung / Härte: vergüteter Stahl/ tempered steel
		Oberflächenbehandlung:
Artikelnummer / ZNR.: 225-1	Dokumentversion: -	Schutzvermerk ISO 16016 beachten