



Nome del prodotto

Estrattore con griffe di estrazione autocentranti

Per l'estrazione di cuscinetti, ingranaggi, pulegge ecc.

Num. art. 225-2

Serie 225

EAN 4021176123412

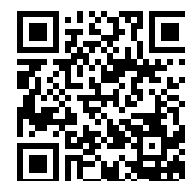

	Attributo tecnico	Metrico	Imperiale
	Ampiezza di serraggio esterna	50 - 70 mm	2 - 2 3/4 inch
	Lunghezza del gancio	25 mm	1 inch
	Peso	1.235 kg	
	Spazio sotto	4 mm	3/16 inch
	Spazio adiacente	14 mm	5/8 inch
	Profondità di serraggio	35 mm	1 3/8 inch



esige anche

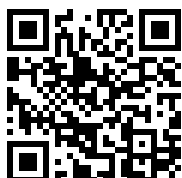

Dispositivi battenti

22-0-1

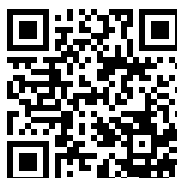

Controsupporti

22-2

Tecnologie



AUTOGRIP

I ganci di estrazione vengono serrati e centrati automaticamente.



é parte di

Num. art.

Nome del prodotto

K-225-1-C

Set di estrattori a 3 bracci con griffe autocentranti

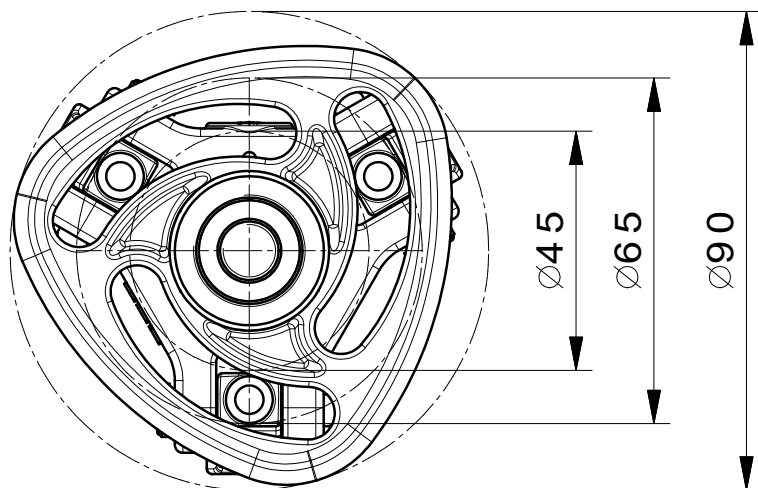
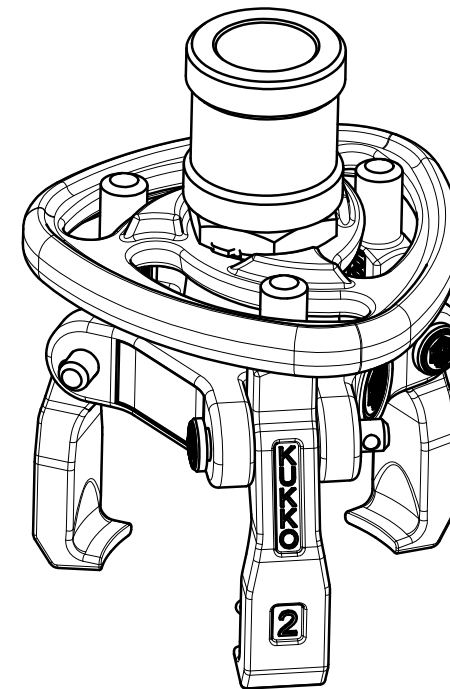
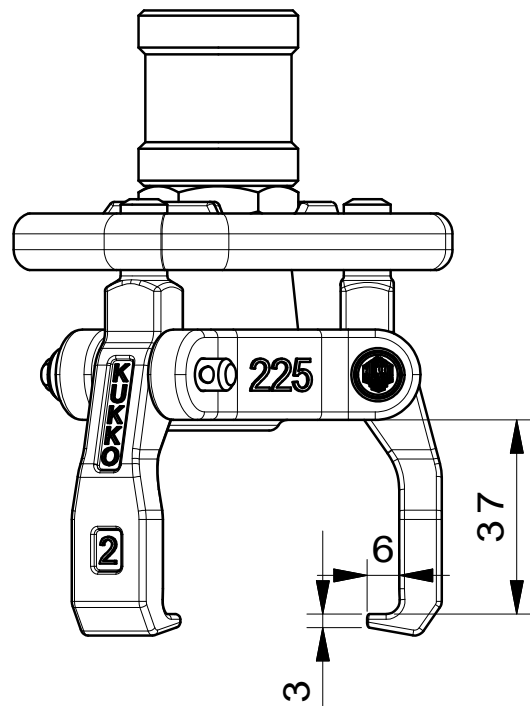
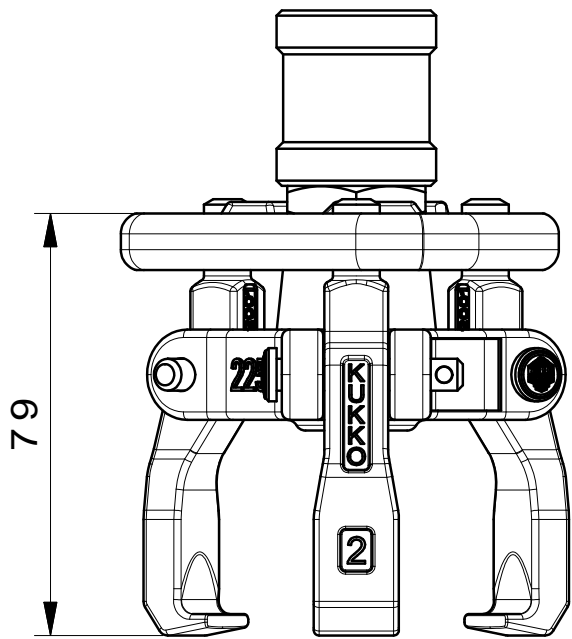

 Kleinbongartz & Kaiser oHG Werkzeugfabrik Hilden - Germany	Dokumentname: 225-2 Staub- und Fettkappenabzieher	Toleranz: DIN ISO 2768-m
	Dokumentbeschreibung: Baugruppe	Material: -
	Erstellt von: Schultes	Erstellungsdatum: 13/04/2016
Teilbeschreibung: Staub- und Fettkappenabzieher/ Extractor with self-centering jaws		Wärmebehandlung / Härte: vergüteter Stahl/ tempered steel
		Oberflächenbehandlung:
Artikelnummer / ZNR.: 225-1	Dokumentversion: -	Schutzvermerk ISO 16016 beachten