



Nome del prodotto

## Estrattore con griffe di estrazione autocentranti

Per l'estrazione di cuscinetti, ingranaggi, pulegge ecc.

Num. art. 225-3

Serie 225

EAN 4021176123429

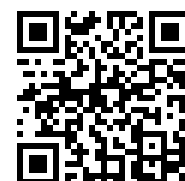

	Attributo tecnico	Metrico	Imperiale
	Ampiezza di serraggio esterna	70 - 90 mm	2 3/4 - 3 1/2 inch
	Lunghezza del gancio	30 mm	1 3/16 inch
	Peso	1.22 kg	
	Spazio sotto	4 mm	3/16 inch
	Spazio adiacente	14 mm	5/8 inch
	Profondità di serraggio	55 mm	2 3/16 inch



esige anche

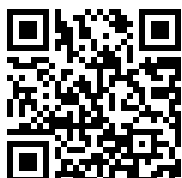

**Dispositivi battenti**

22-0-1



**Controsupporti**

22-2

## Tecnologie



### **AUTOGRIP**

I ganci di estrazione vengono serrati e centrati automaticamente.



é parte di

**Num. art.**

**Nome del prodotto**

K-225-1-C

Set di estrattori a 3 bracci con griffe autocentranti

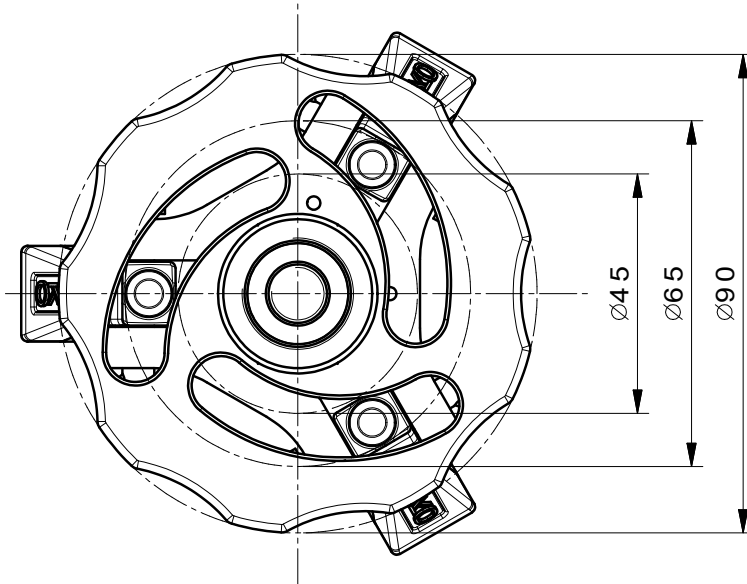
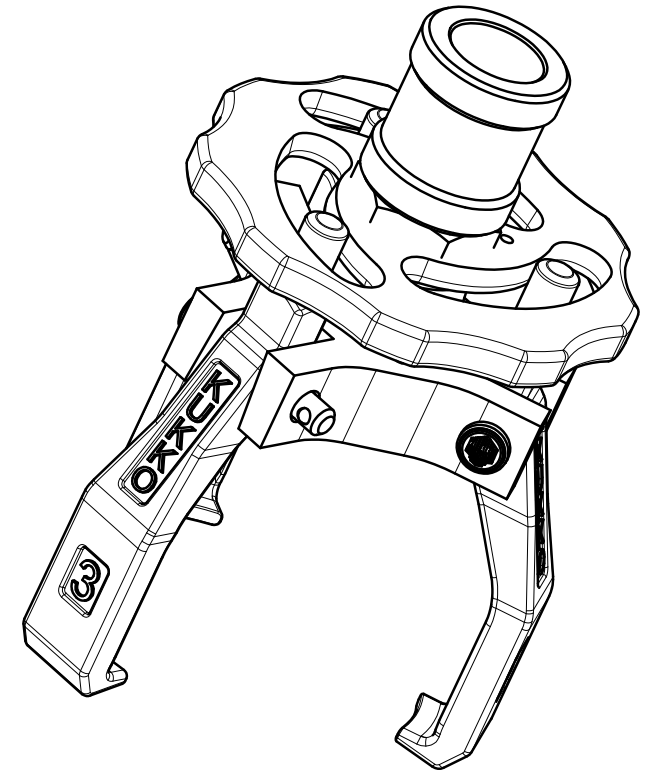
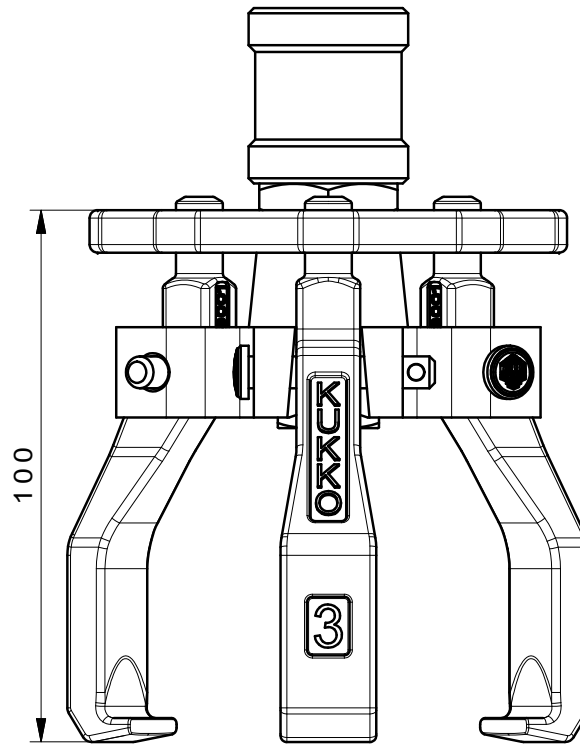
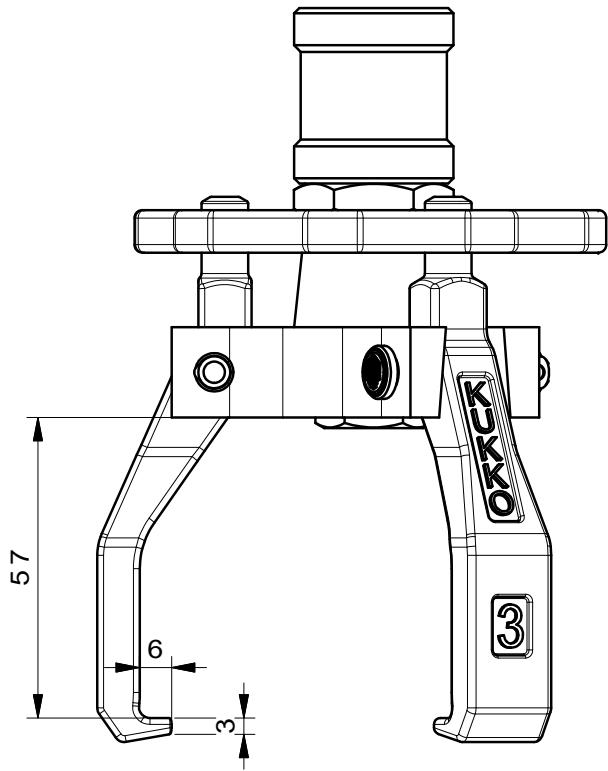

 <b>Kleinbongartz &amp; Kaiser oHG</b> Werkzeugfabrik Hilden - Germany	Dokumentname: 225-3 Staub- und Fettkappenabzieher	Toleranz: DIN ISO 2768-m
	Dokumentbeschreibung: Baugruppe	Material: Hoch legierter Werkzeugstahl / High alloy tool steel
Erstellt von: Schultes	Erstellungsdatum: 13/04/2016	Maßstab: 1:1
Teilbeschreibung: Staub- und Fettkappenabzieher/ Extractor with self-centering jaws		Wärmebehandlung / Härte: vergüteter Stahl/ tempered steel
Oberflächenbehandlung:		
Artikelnummer / ZNR.: 225-3	Dokumentversion: -	Schutzvermerk ISO 16016 beachten