



Product name *

Universal 3-jaw puller with narrow jaws

For removing bearings, gears, discs, etc. for tight or difficult-to-access spaces.

Art. No. 30-1-S

Series 30-S

EAN 4021176727771



	Technical attribute	Metric	Imperial
	Spread	27 - 90 mm	1 1/16 - 3 1/2 inch
	Depth	100 mm	3 7/8 inch
	Spread used internal	70 - 140 mm	2 3/4 - 5 1/2 inch
	Hexagon drive (male)	17 mm	
max.	Maximum load	3 t	3 US t
	Maximum torque	40 Nm	29.5 ft lb
	Weight	1.335 kg	
	Space below	2,6 mm	1/8 inch
	Space next to it	14 mm	5/8 inch
	Number of jaws	3	3



Technologies



GLIDE & FIX

The improved geometry guarantees quick and easy movement of the jaws on the cross-beam.



ARMLOCK

The cross-legged jaws guarantee maximum stability for suspending the jaws in the slider.



SWITCH

A two-sided spindle tip provides optimal adjustment of the spindle to the shaft.



Spare part

Art. No.	Product name
614135	Mechanical pressure spindle.
1-91-S	3 narrow jaws (set)
30-1-T	3-jaw cross bar

Accessories

Art. No.	Product name
1-90-S	3 pulling arms (set)
1-190-S	3 pulling arms (set)
1-250-S	3 pulling arms (set)
1-400-S	3 pulling arms (set)
1-91-S	3 narrow jaws (set)
1-191-S	3 narrow jaws (set)
1-251-S	3 narrow jaws (set)
1-94-S	3 extremely narrow jaws (set)
1-194-S	3 extremely narrow jaws (set)
1-254-S	3 extremely narrow jaws (set)
1-V-100-S	3 jaw extensions (set)
1-V-150-S	3 jaw extensions (set)
K-600-014	Set of interchangeable pressure pads for KUKKO pressure screws



Also included in

Art. No.

Product name

WT-004

Puller product range - automotive - BASIC

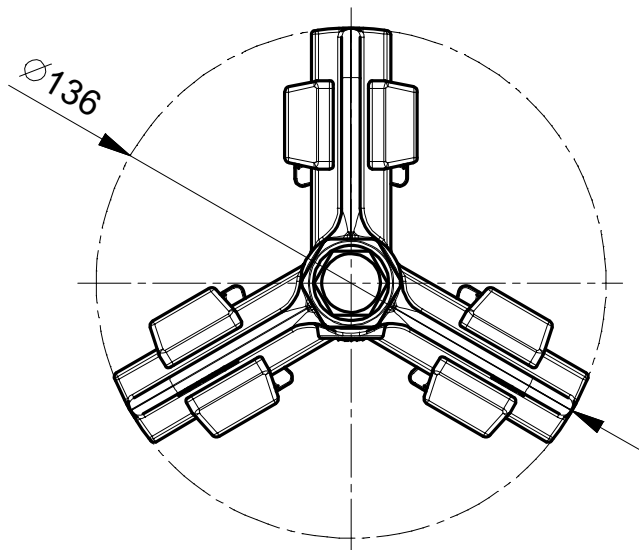
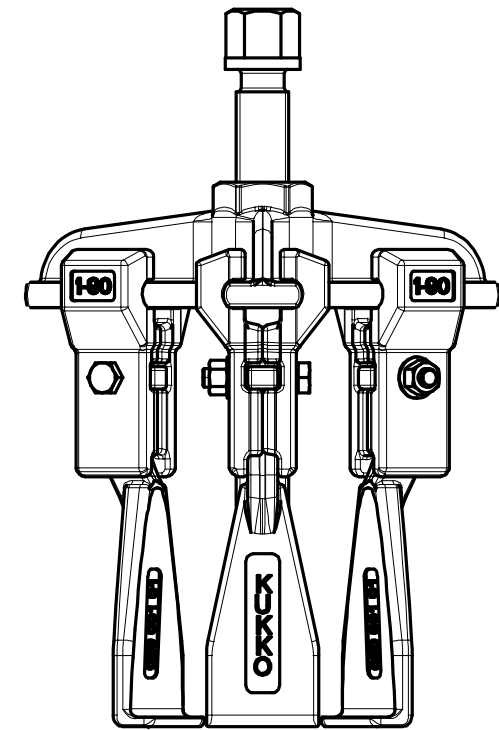
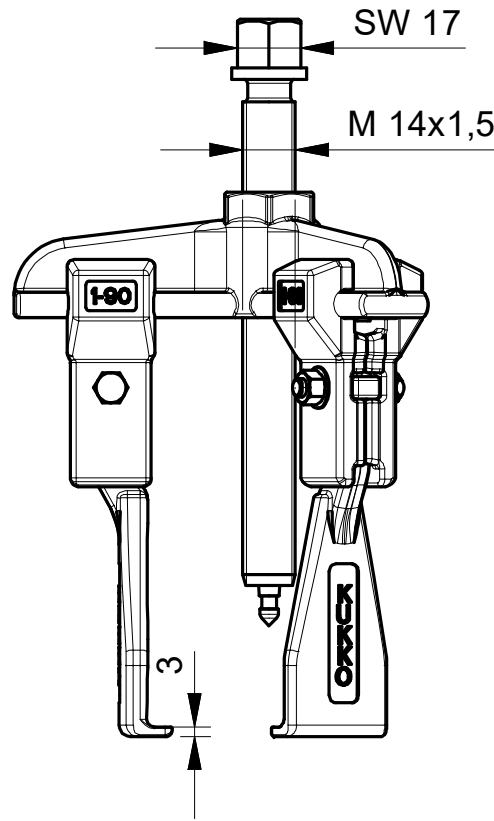
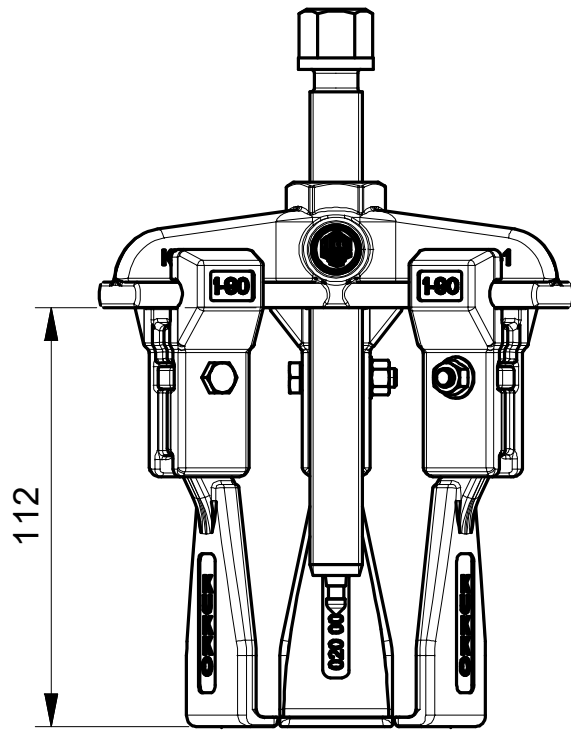

 Kleinbongartz & Kaiser oHG Werkzeugfabrik Hilden - Germany	Dokumentname: 30-1-S_Universal Abzieher		Toleranz: DIN ISO 2768-m	
	Dokumentbeschreibung: Baugruppe		Material: Hoch legierter Werkzeugstahl / High alloy tool steel	
	Erstellt von: Breidenbach	Erstellungsdatum: 02/05/2018		Maßstab: 1:2
Teilbeschreibung: Universal Abzieher schmale Abzugshaken/ Universal 3-jaw puller with narrow jaws			Wärmebehandlung / Härte: vergüteter Stahl/ tempered steel	
Oberflächenbehandlung:			Schutzvermerk ISO 16016 beachten	
Artikelnummer / ZNR.: 30-1-S		Dokumentversion: -		