



Ürün adı \*

## Dar çekirme kollarına sahip 3 kollu üniversal çekirme

Dar ve erişilmesi zor alanlarda yatakların, dişlilerin ve rondelaların çekirilmesi için.

Ürün No. 30-1-S

Seriler 30-S

EAN 4021176727771



	<b>Teknik özellik</b>	<b>Metrik</b>	<b>Imparatorluk</b>
	Açılma genişliği	27 - 90 mm	1 1/16 - 3 1/2 inch
	Derinlik	100 mm	3 7/8 inch
	İç çekirme açılma genişliği	70 - 140 mm	2 3/4 - 5 1/2 inch
	Altıköşe geçme (erkek)	17 mm	
max.	İzin verilen maksimum yük	3 t	3 US t
	Maks. tork	40 Nm	29.5 ft lb
	Ağırlık	1.335 kg	
	Raum unterhalb	2,6 mm	1/8 inch
	Raum nebendran	14 mm	5/8 inch
	Çene sayısı	3	3



## Teknolojiler



### GLIDE & FIX

Optimal geometri çenenin giriş üzerinde kolayca ve hızlı kaydırılmasına izin verir.



### ARMLOCK

Çapraz kancalar çenenin kayar parça içine asılmasında azami denge sağlar.



### SWITCH

İki taraflı mil ucu sayesinde milin şaftla optimum uyumu.



## Yedek parça

Ürün No.	Ürün adı
614135	Mekanik mil
1-91-S	3 dar çektirme kolu (çift)
30-1-T	3 kollu çektirme gövdesi

## Aksesuarlar

Ürün No.	Ürün adı
1-90-S	3 çektirme kolu (set)
1-190-S	3 çektirme kolu (set)
1-250-S	3 çektirme kolu (set)
1-400-S	3 çektirme kolu (set)
1-91-S	3 dar çektirme kolu (çift)
1-191-S	3 dar çektirme kolu (çift)
1-251-S	3 dar çektirme kolu (çift)
1-94-S	3 çok dar çektirme kolu (set)
1-194-S	3 çok dar çektirme kolu (set)
1-254-S	3 çok dar çektirme kolu (set)
1-V-100-S	3 çektirme kolu uzatması (set)
1-V-150-S	3 çektirme kolu uzatması (set)
K-600-014	KUKKO Milleri için, "6'sı 1 arada" değiştirilebilir Mil Uç Geçme Parçaları



## De içinde bulunur

**Ürün No.**

**Ürün adı**

WT-004

Çektirme ürün yelpazesi - otomotiv - BASIC

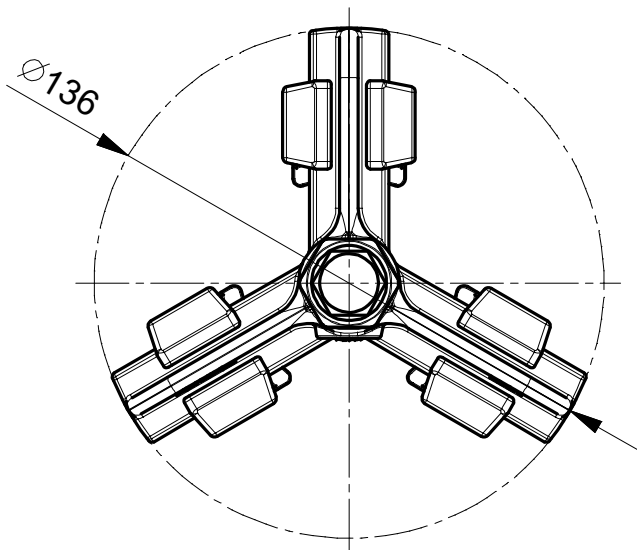
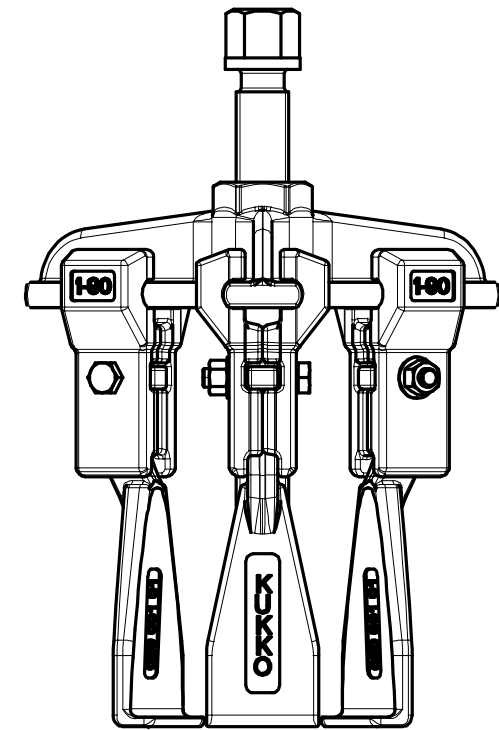
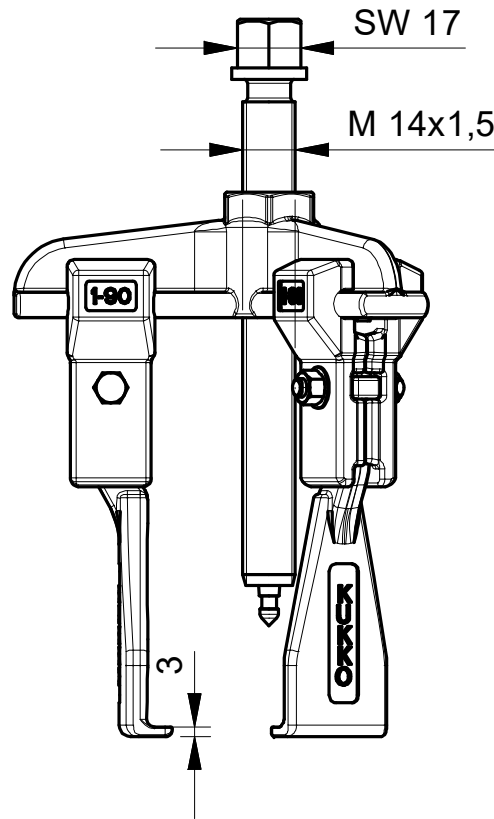
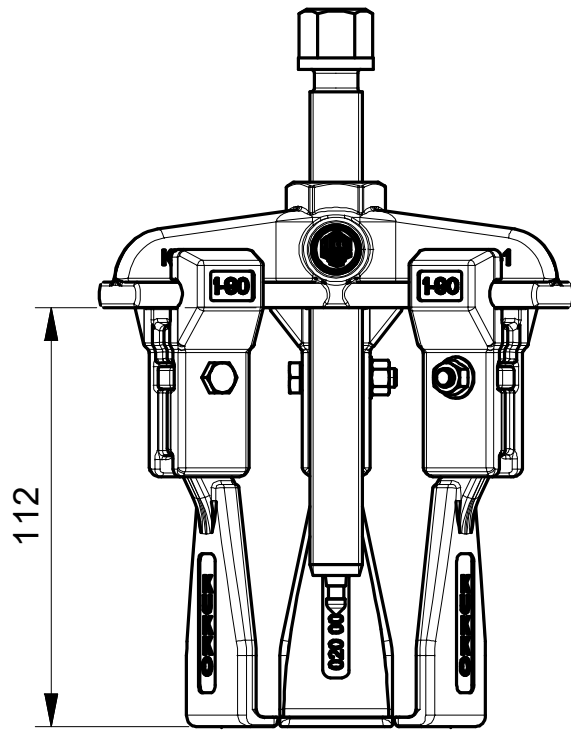

 <p><b>Kleinbongartz &amp; Kaiser oHG</b> Werkzeugfabrik Hilden - Germany</p>	Dokumentname: 30-1-S_Universal Abzieher		Toleranz: DIN ISO 2768-m	
	Dokumentbeschreibung: Baugruppe		Material: Hoch legierter Werkzeugstahl / High alloy tool steel	
	Erstellt von: Breidenbach	Erstellungsdatum: 02/05/2018		Maßstab: 1:2
Teilbeschreibung:  Universal Abzieher schmale Abzugshaken/ Universal 3-jaw puller with narrow jaws			Wärmebehandlung / Härte: vergüteter Stahl/ tempered steel	
Oberflächenbehandlung:			Schutzvermerk ISO 16016 beachten	
Artikelnummer / ZNR.: 30-1-S		Dokumentversion: -		