



Nome del prodotto

Estrattore universale a 3 bracci con griffe sottili

Per l'estrazione di cuscinetti, ingranaggi, pulegge, ecc. per spazi ristretti e difficili da raggiungere.

Num. art. 30-10-S

Serie 30-S

EAN 4021176728198

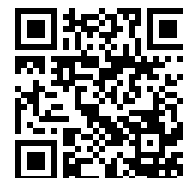

	Attributo tecnico	Metrico	Imperiale
	Ampiezza di serraggio esterna	27 - 130 mm	1 1/16 - 5 1/8 inch
	Profondità di serraggio	100 mm	3 7/8 inch
	Ampiezza di serraggio interna	70 - 180 mm	2 3/4 - 7 1/8 inch
	Esagono esterno	17 mm	
max.	Carico massimo consentito	3 t	3 US t
	Coppia massima	40 Nm	29.5 ft lb
	Peso	1.52 kg	
	Spazio sotto	2,6 mm	1/8 inch
	Spazio adiacente	14 mm	5/8 inch
	Numero delle griffe	3	3



Tecnologie



GLIDE & FIX

La geometria ottimizzata garantisce una scorrevolezza facile e rapida dei ganci di estrazione sulla traversa.



ARMLOCK

I ganci a croce garantiscono la massima stabilità per la sospensione dei ganci di estrazione nel pezzo scorrevole.



SWITCH

Adattamento ottimale dei mandrini all'albero grazie alla punta bilaterale dei mandrini.



Pezzo di ricambio

Num. art.	Nome del prodotto
614135	Vite di pressione meccanica.
1-91-S	3 griffe sottili (set)
30-10-T	Traversa

Acessori

Num. art.	Nome del prodotto
1-91-S	3 griffe sottili (set)
1-191-S	3 griffe sottili (set)
1-251-S	3 griffe sottili (set)
1-401-S	3 griffe sottili (set)
1-94-S	3 griffe estremamente sottili (set)
1-194-S	3 griffe estremamente sottili (set)
1-254-S	3 griffe estremamente sottili (set)
1-V-100-S	3 prolunghe per griffe (set)
1-V-150-S	3 prolunghe per griffe (set)
K-600-014	Set di pressori intercambiabili per viti di pressione KUKKO



é incluso anche in

Num. art.

Nome del prodotto

K-2030-10-S

Set di estrattori universali a 2 e 3 bracci con griffe sottili

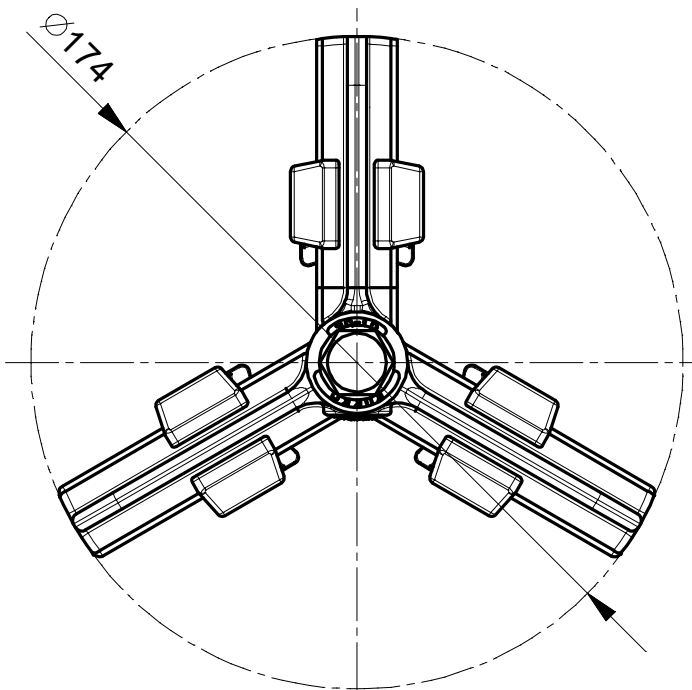
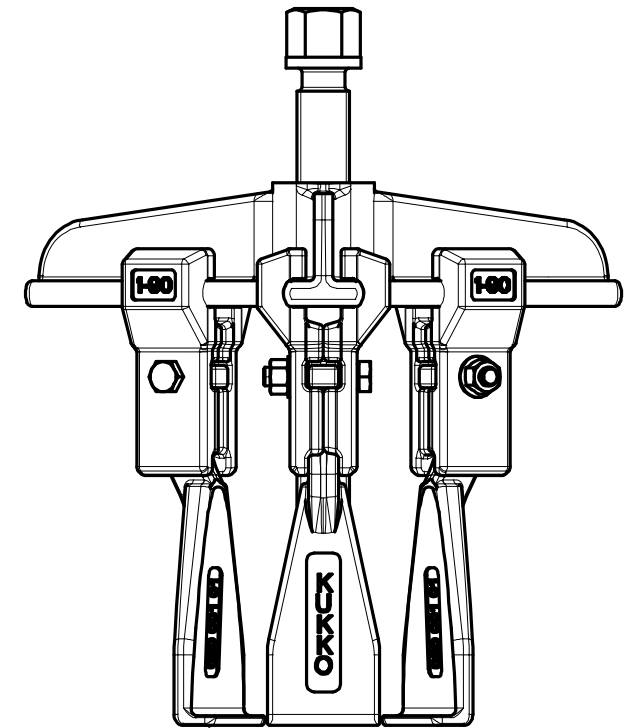
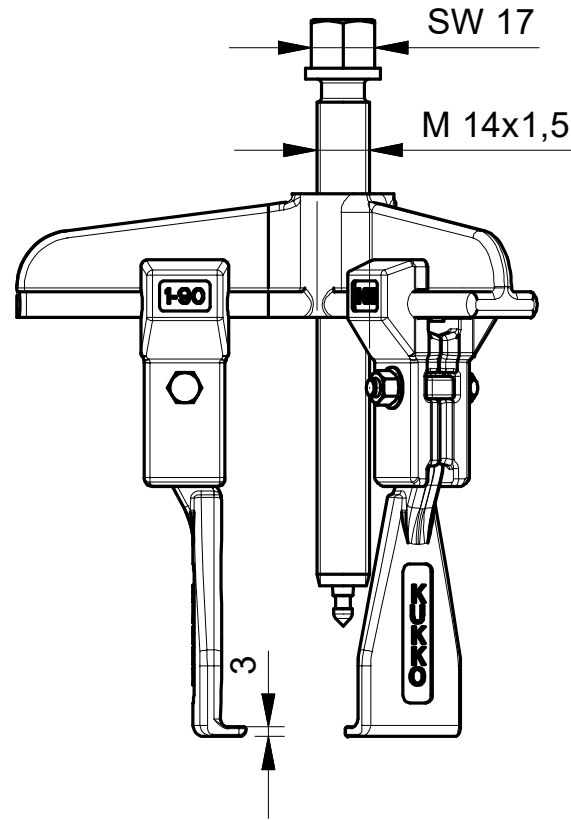
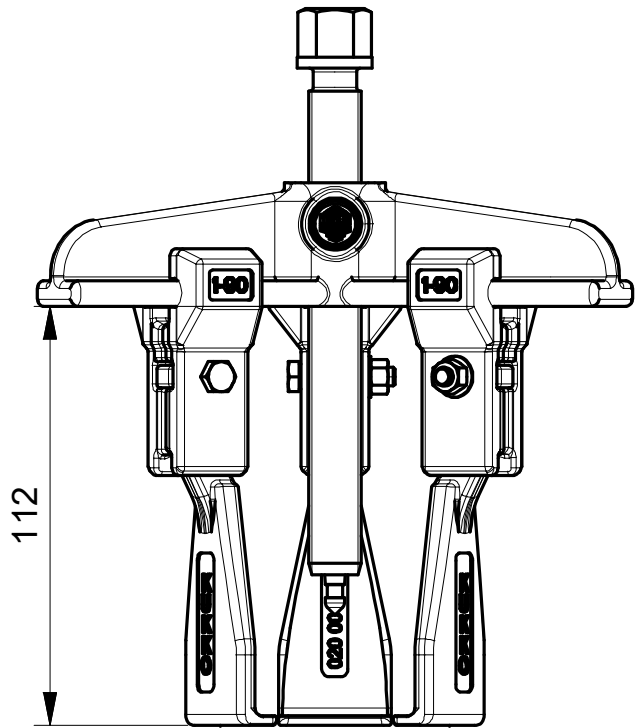

 <p>Kleinbongartz & Kaiser oHG Werkzeugfabrik Hilden - Germany</p>	Dokumentname: 30-10-S_Universal Abzieher		Toleranz: DIN ISO 2768-m	
	Dokumentbeschreibung: Baugruppe		Material: Hoch legierter Werkzeugstahl / High alloy tool steel	
	Erstellt von: Breidenbach	Erstellungsdatum: 02/05/2018	Maßstab: 1:2	
Teilbeschreibung: Universal Abzieher schmale Abzugshaken/ Universal 3-jaw puller with narrow jaws			Wärmebehandlung / Härte: vergüteter Stahl/ tempered steel	
Oberflächenbehandlung:			Schutzvermerk ISO 16016 beachten	
Artikelnummer / ZNR.: 30-10-S		Dokumentversion: -		