



Productnaam

3-armige universele trekker met dunne trekhaken

Voor het trekken van lagers, tandwielen, schijven enz voor nauwe tussenruimtes

Art nr. 30-10-S

Serie 30-S

EAN 4021176728198

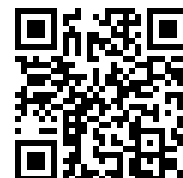

| | Technisch kenmerk | Metrisch | Imperial |
|------|-------------------------------|-------------|---------------------|
| | Spanwijdte, uitwendig | 27 - 130 mm | 1 1/16 - 5 1/8 inch |
| | Spandiepte | 100 mm | 3 7/8 inch |
| | Spanwijdte inwendig | 70 - 180 mm | 2 3/4 - 7 1/8 inch |
| | Buitenzeskant | 17 mm | |
| max. | Maximaal toegestane belasting | 3 t | 3 US t |
| | Max. aandraaimoment | 40 Nm | 29.5 ft lb |
| | Gewicht | 1.52 kg | |
| | Ruimte beneden | 2,6 mm | 1/8 inch |
| | Raum nebendran | 14 mm | 5/8 inch |
| | Aantal haken | 3 | 3 |



Technologieën



GLIDE & FIX

De geoptimaliseerde geometrie waarborgt dat de trekhaken makkelijk en snel verschoven kunnen worden op de traverse.



ARMLOCK

De kruishaken waarborgen maximale stabiliteit voor de ophanging van de trekhaken in het glijstuk.



SWITCH

Optimale aanpassing van de spil aan de as dankzij de dubbele spilkop.



Onderdeel

| Art nr. | Productnaam |
|----------------|-------------------------|
| 614135 | Mechanische spindels. |
| 1-91-S | 3 dunne trekhaken (set) |
| 30-10-T | Brug |

Toebehoren

| Art nr. | Productnaam |
|----------------|--|
| 1-91-S | 3 dunne trekhaken (set) |
| 1-191-S | 3 dunne trekhaken (set) |
| 1-251-S | 3 dunne trekhaken (set) |
| 1-401-S | 3 dunne trekhaken (set) |
| 1-94-S | 3 extreem dunne trekhaken (set) |
| 1-194-S | 3 extreem dunne trekhaken (set) |
| 1-254-S | 3 extreem dunne trekhaken (set) |
| 1-V-100-S | 3 trekhaak verlengstukken (set) |
| 1-V-150-S | 3 trekhaak verlengstukken (set) |
| K-600-014 | Wisseldrukstukkenset voor KUKKO spindels |



Zit ook in

Art nr.

Productnaam

K-2030-10-S

2- en 3-armige universele trekker-set met dunne trekhaken

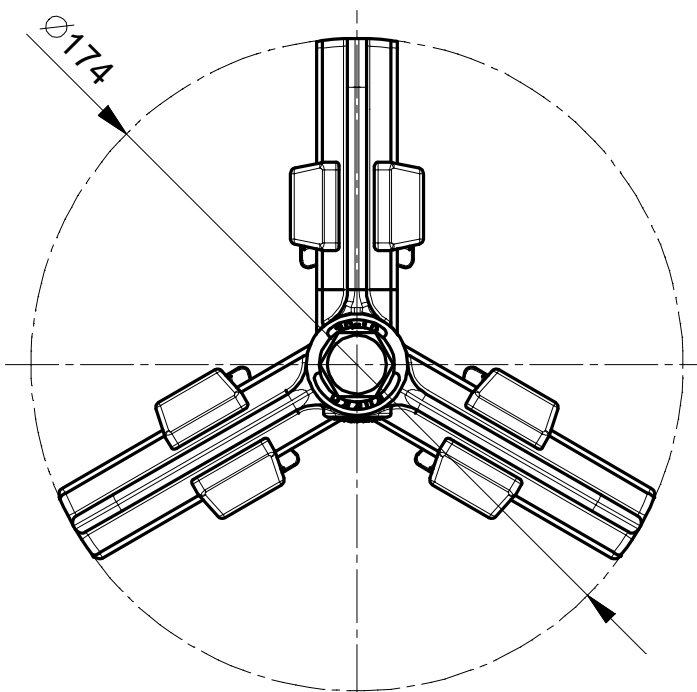
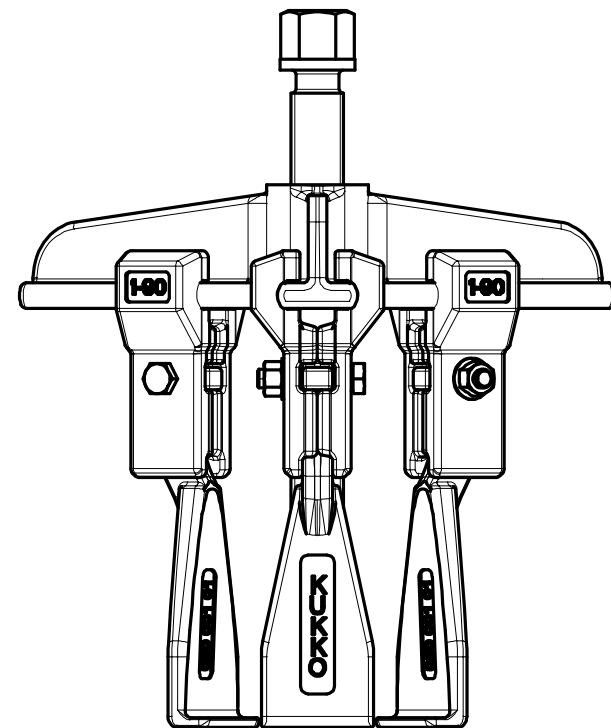
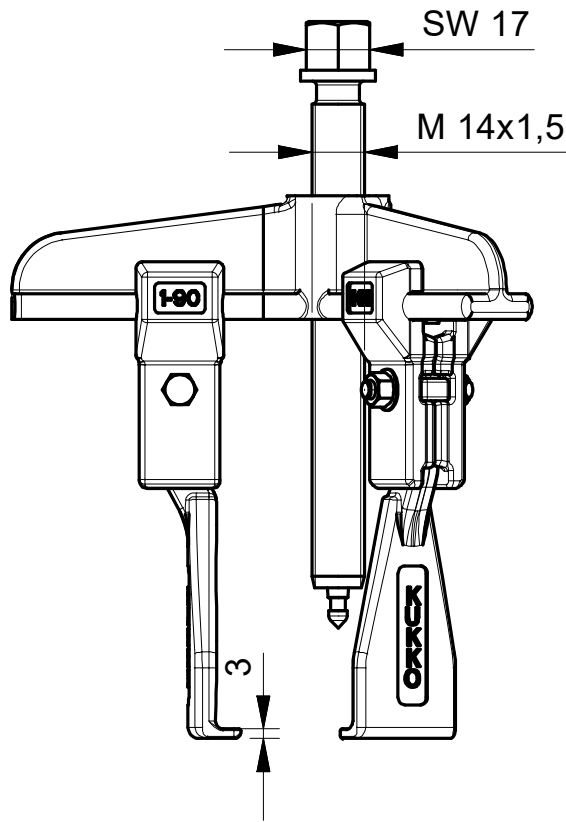
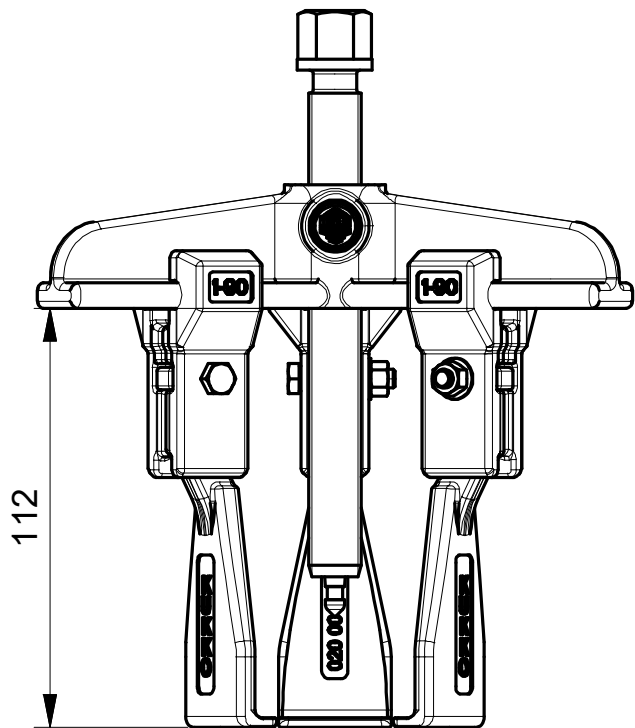

| | | | | |
|---|--|--|--|------------------------|
|  Kleinbongartz & Kaiser oHG Werkzeugfabrik Hilden - Germany | Dokumentname: 30-10-S_Universal Abzieher | | Toleranz: DIN ISO 2768-m | |
| | Dokumentbeschreibung: Baugruppe | | Material: Hoch legierter Werkzeugstahl / High alloy tool steel | |
| | Erstellt von: Breidenbach | Erstellungsdatum: 02/05/2018 | | Maßstab: 1:2 |
| Teilbeschreibung: Universal Abzieher schmale Abzugshaken/ Universal 3-jaw puller with narrow jaws | | | Wärmebehandlung / Härte: vergüteter Stahl/ tempered steel | |
| Oberflächenbehandlung: | | | Schutzvermerk ISO 16016 beachten | |
| Artikelnummer / ZNR.: 30-10-S | | Dokumentversion: - | | |