



Produktnavn

3-armet universalaftrækker









Til aftrækning af lejer, tandhjul, skiver etc.

Varenr. 30-10

Serie 30

EAN 4021176013621



	Teknisk egenskab	Metrisk	Tomme
	Spændvidde udvendig	27 - 130 mm	1 1/16 - 5 1/8 inch
	Spænddybde	100 mm	3 7/8 inch
	Spændvidde indvendig	70 - 180 mm	2 3/4 - 7 1/8 inch
	Udvendig sekskant	17 mm	
max.	Maksimal tilladt belastning	6 t	6.5 US t
	Maks. drejningsmoment	80 Nm	59 ft lb
	Vægt	1.59 kg	
	Rum nedenunder	10 mm	3/8 inch
	Rum ved siden af	31 mm	1 1/4 inch
	Antal kroge	3	3



Teknologier



SWITCH

Optimal spindeltilpasning til akslen gennem spindelspidser på to sider.



GLIDE & FIX

Den optimerede geometri garanterer en nem og hurtig bevægelse af aftrækkerkroge på tværstangen.



ARMLOCK

Tværkroge garanterer maksimal stabilitet for ophængningen af aftrækkerkroge på glidestykket.



Reservedel

Varenr.	Produktnavn
614135	Mekanisk trykspindel.
1-90-S	3 aftrækningskroge (sæt)
30-10-T	Travers

Tilbehør

Varenr.	Produktnavn
K-600-014	Sæt med udskiftelige trykstykker til KUKKO-trykspindler

Gå med

Varenr.	Produktnavn
13-TP-1	Adskiller med 3 segmenter



Indgår også i

Varenr.

Produktnavn

K-2030-10

2- og 3-armet universalaftrækkersæt

30-20-T

Aftrækkersortimenter - industri - BASIC

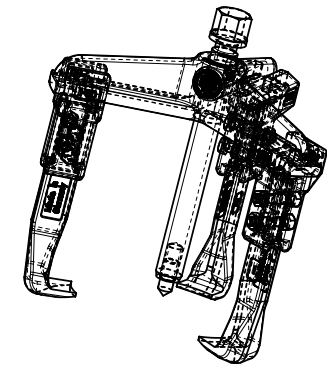
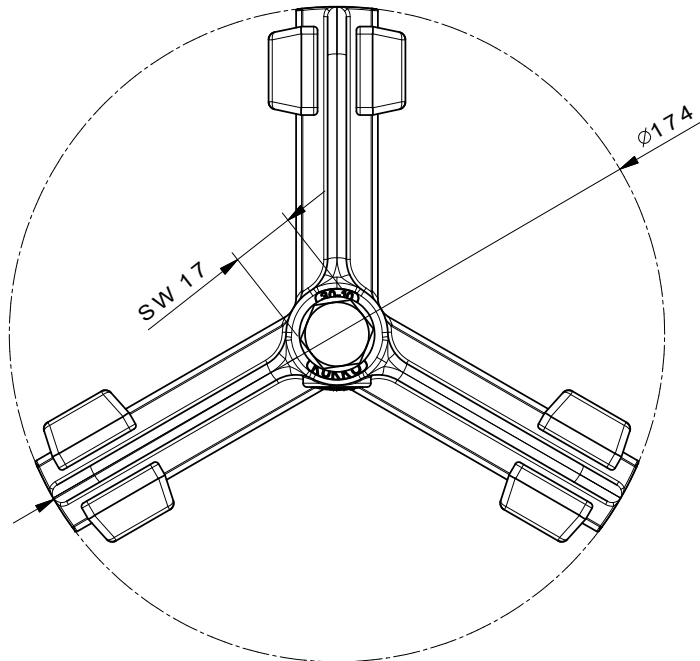
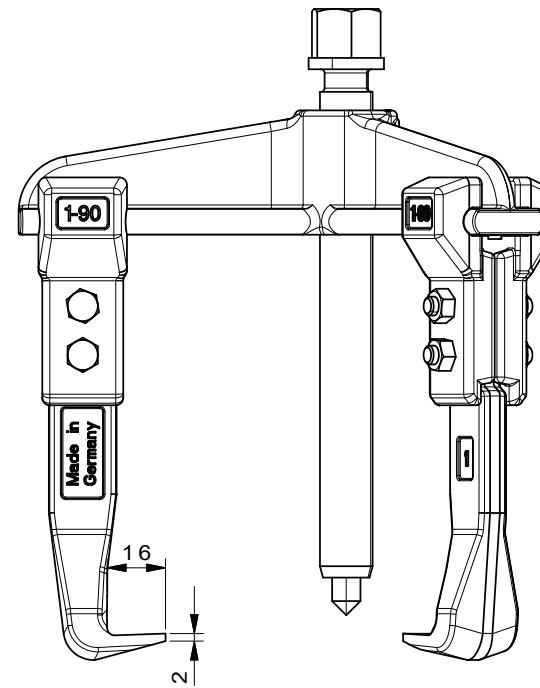
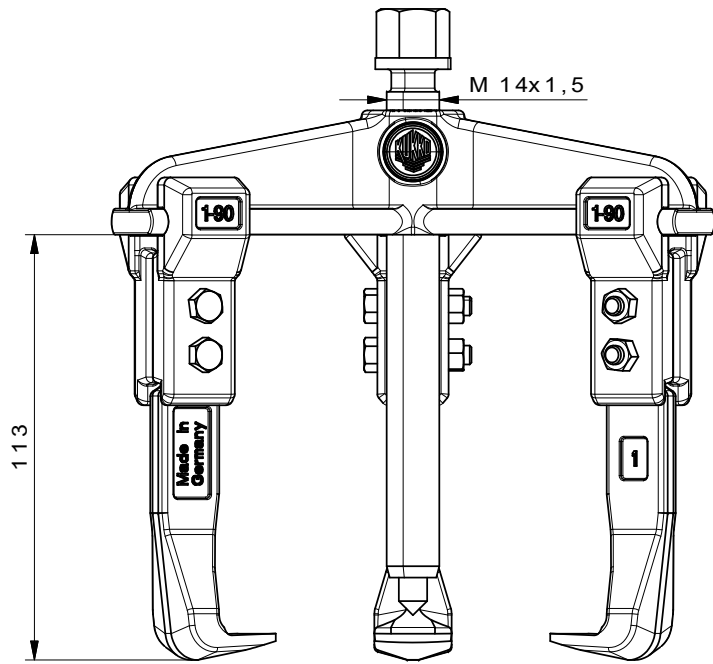

 Kleinbongartz & Kaiser oHG Werkzeugfabrik Hilden - Germany	Dokumentname: 30-10_3-Arm-Universal_Abzieher	Toleranz: DIN ISO 2768-m
	Dokumentbeschreibung: Baugruppe	Material: Hoch legierter Werkzeugstahl / High alloy tool steel
Erstellt von: Breidenbach	Erstellungsdatum: 30/03/2015	Maßstab: 1:1
Teilbeschreibung: 3-Arm-Universal_Abzieher/ Universal 3-jaw puller with narrow jaws		Wärmebehandlung / Härte: vergüteter Stahl/ tempered steel
Artikelnummer / ZNR.: 30-10		Oberflächenbehandlung: Schutzvermerk ISO 16016 beachten