



Product name

Universal 3-jaw puller

For removing bearings, gears, discs, etc.

Art. No. 30-10

Series 30

EAN 4021176013621



	Technical attribute	Metric	Imperial
	Spread	27 - 130 mm	1 1/16 - 5 1/8 inch
	Depth	100 mm	3 7/8 inch
	Spread used internal	70 - 180 mm	2 3/4 - 7 1/8 inch
	Hexagon drive (male)	17 mm	
	Maximum load	6 t	6.5 US t
	Maximum torque	80 Nm	59 ft lb
	Weight	1.59 kg	
	Space below	10 mm	3/8 inch
	Space next to it	31 mm	1 1/4 inch
	Number of jaws	3	3



Technologies



SWITCH

A two-sided spindle tip provides optimal adjustment of the spindle to the shaft.



GLIDE & FIX

The improved geometry guarantees quick and easy movement of the jaws on the cross-beam.

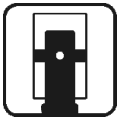

ARMLOCK

The cross-legged jaws guarantee maximum stability for suspending the jaws in the slider.



Spare part

Art. No.	Product name
614135	Mechanical pressure spindle.
1-90-S	3 pulling arms (set)
30-10-T	Cross-beam

Accessories

Art. No.	Product name
K-600-014	Set of interchangeable pressure pads for KUKKO pressure screws

Goes with

Art. No.	Product name
13-TP-1	Seperators with 3 segments



Also included in

Art. No.

Product name

K-2030-10

Set of universal 2- and 3-jaw pullers

30-20-T

Puller product range - industrial - BASIC

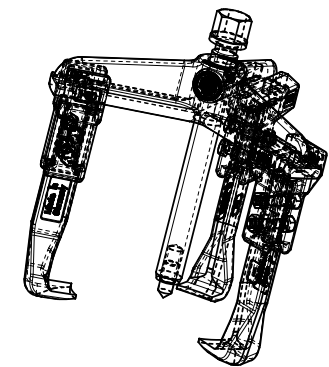
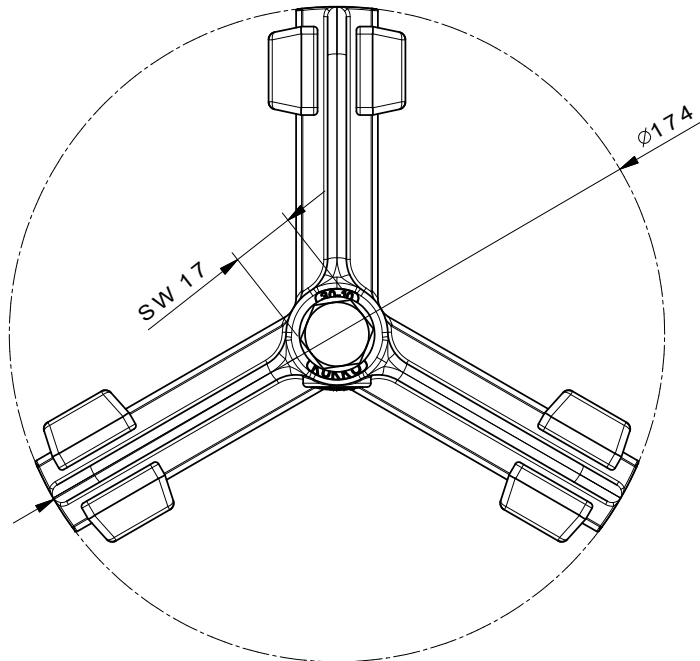
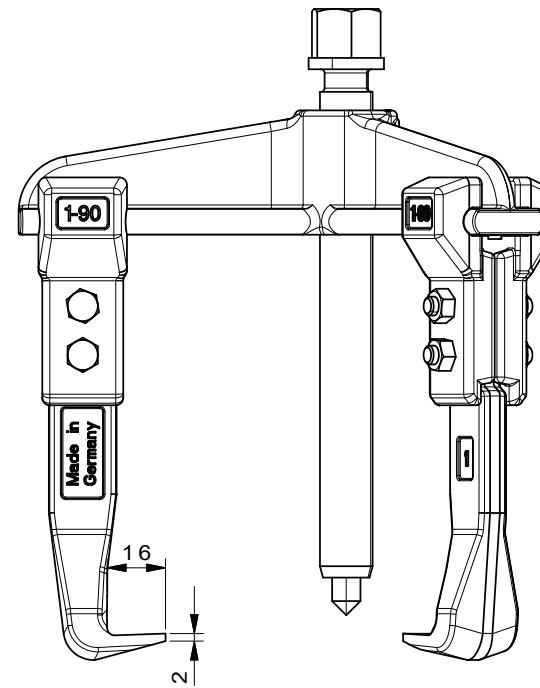
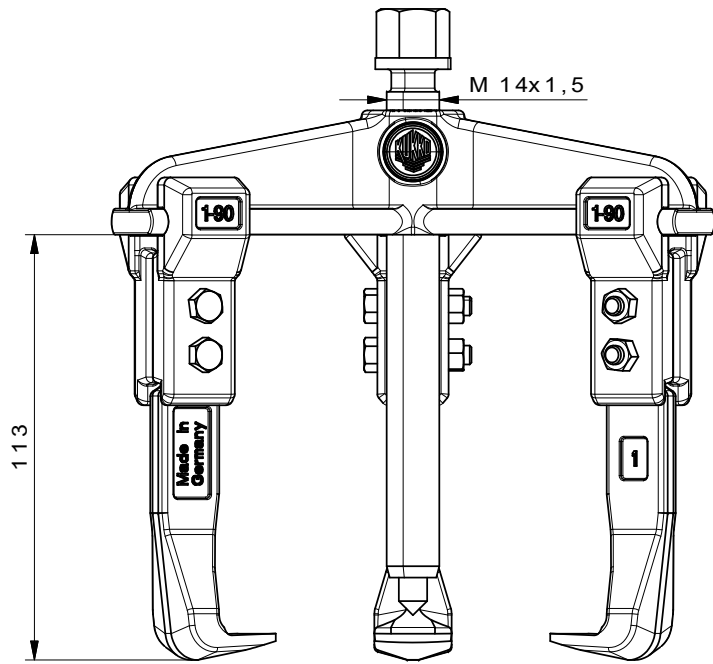

 Kleinbongartz & Kaiser oHG Werkzeugfabrik Hilden - Germany	Dokumentname: 30-10_3-Arm-Universal_Abzieher	Toleranz: DIN ISO 2768-m
	Dokumentbeschreibung: Baugruppe	Material: Hoch legierter Werkzeugstahl / High alloy tool steel
Erstellt von: Breidenbach	Erstellungsdatum: 30/03/2015	Maßstab: 1:1
Teilbeschreibung: 3-Arm-Universal_Abzieher/ Universal 3-jaw puller with narrow jaws		Wärmebehandlung / Härte: vergüteter Stahl/ tempered steel
Oberflächenbehandlung:		Schutzvermerk ISO 16016 beachten
Artikelnummer / ZNR.: 30-10	Dokumentversion: -	