



Nome del prodotto

Estrattore universale a 3 bracci

Per l'estrazione di cuscinetti, ingranaggi, pulegge ecc.

Num. art. 30-10

Serie 30

EAN 4021176013621



	Attributo tecnico	Metrico	Imperiale
	Ampiezza di serraggio esterna	27 - 130 mm	1 1/16 - 5 1/8 inch
	Profondità di serraggio	100 mm	3 7/8 inch
	Ampiezza di serraggio interna	70 - 180 mm	2 3/4 - 7 1/8 inch
	Esagono esterno	17 mm	
max.	Carico massimo consentito	6 t	6.5 US t
	Coppia massima	80 Nm	59 ft lb
	Peso	1.59 kg	
	Spazio sotto	10 mm	3/8 inch
	Spazio adiacente	31 mm	1 1/4 inch
	Numero delle griffe	3	3



Tecnologie



SWITCH

Adattamento ottimale dei mandrini all'albero grazie alla punta bilaterale dei mandrini.



GLIDE & FIX

La geometria ottimizzata garantisce una scorrevolezza facile e rapida dei ganci di estrazione sulla traversa.



ARMLOCK

I ganci a croce garantiscono la massima stabilità per la sospensione dei ganci di estrazione nel pezzo scorrevole.



Pezzo di ricambio

Num. art.	Nome del prodotto
614135	Vite di pressione meccanica.
1-90-S	3 griffe (set)
30-10-T	Traversa

Acessori

Num. art.	Nome del prodotto
K-600-014	Set di pressori intercambiabili per viti di pressione KUKKO

Viene utilizzato da

Num. art.	Nome del prodotto
13-TP-1	Separatore a 3 segmenti



é incluso anche in

Num. art.	Nome del prodotto
K-2030-10	Set di estrattori universali a 2 e 3 bracci
30-20-T	Assortimento estrattori - Industria - BASIC

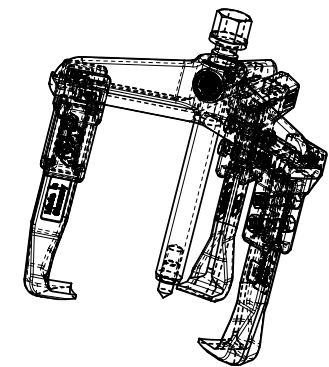
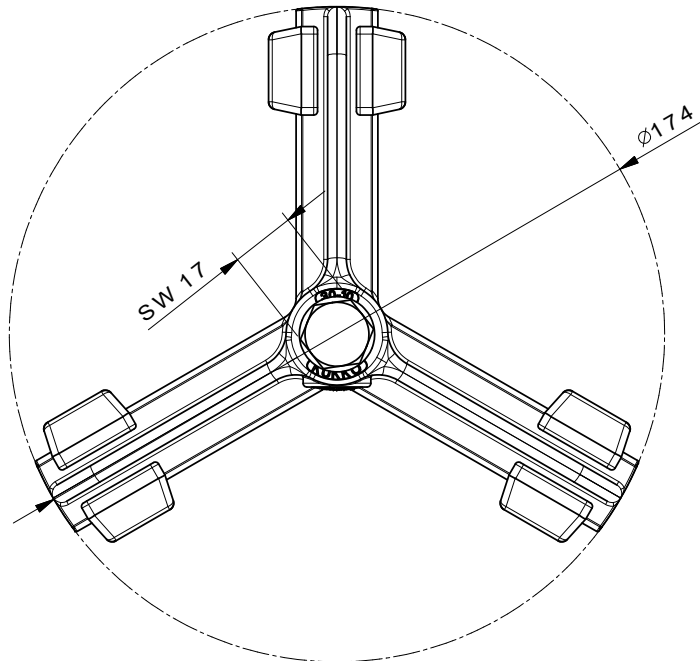
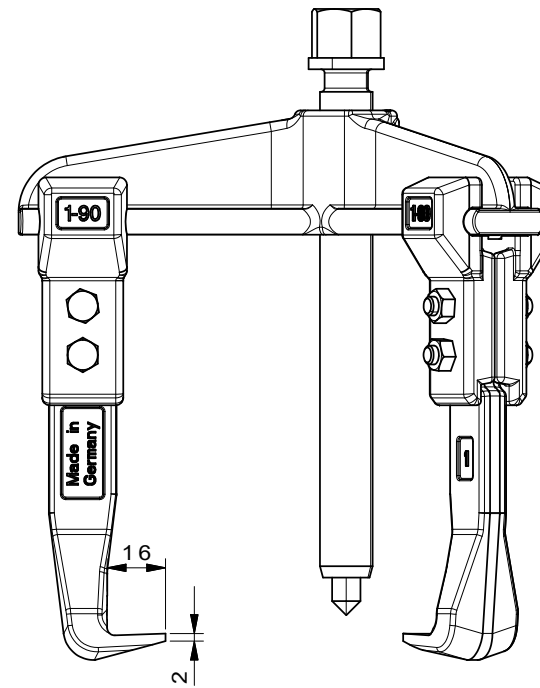
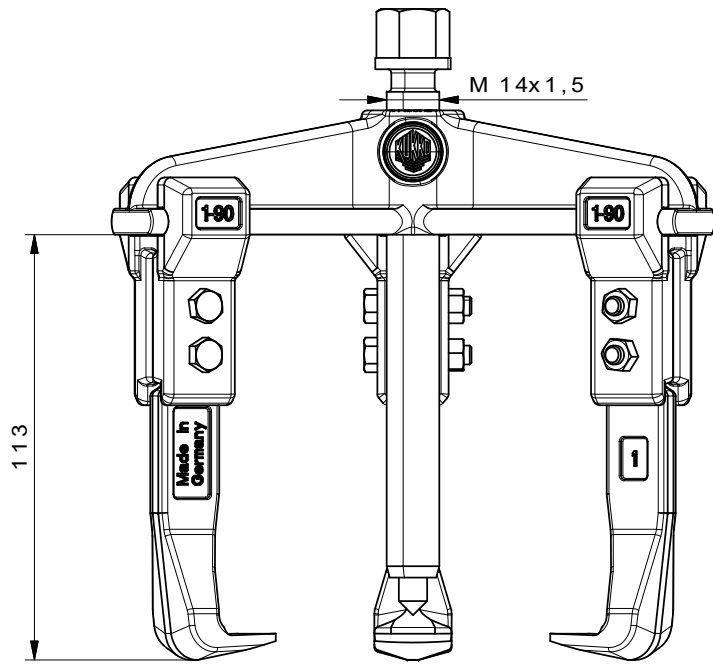

 Kleinbongartz & Kaiser oHG Werkzeugfabrik Hilden - Germany	Dokumentname: 30-10_3-Arm-Universal_Abzieher	Toleranz: DIN ISO 2768-m
	Dokumentbeschreibung: Baugruppe	Material: Hoch legierter Werkzeugstahl / High alloy tool steel
Erstellt von: Breidenbach	Erstellungsdatum: 30/03/2015	Maßstab: 1:1
Teilbeschreibung: 3-Arm-Universal_Abzieher/ Universal 3-jaw puller with narrow jaws		Wärmebehandlung / Härte: vergüteter Stahl/ tempered steel
Oberflächenbehandlung:		Schutzvermerk ISO 16016 beachten
Artikelnummer / ZNR.: 30-10	Dokumentversion: -	