



Ürün adı

## 3 kollu üniversal çekirme

Yatakları, dişlileri, rondelaları vb. çıkarmak için.

Ürün No. 30-10

Seriler 30

EAN 4021176013621



### Teknik özellik

### Metrik

### Imparatorluk

	Teknik özellik	Metrik	Imparatorluk
	Açılma genişliği	27 - 130 mm	1 1/16 - 5 1/8 inch
	Derinlik	100 mm	3 7/8 inch
	İç çekirme açılma genişliği	70 - 180 mm	2 3/4 - 7 1/8 inch
	Altıköşe geçme (erkek)	17 mm	
max.	İzin verilen maksimum yük	6 t	6.5 US t
	Maks. tork	80 Nm	59 ft lb
	Ağırlık	1.59 kg	
	Raum unterhalb	10 mm	3/8 inch
	Raum nebendran	31 mm	1 1/4 inch
	Çene sayısı	3	3



## Teknolojiler



### SWITCH

İki taraflı mil ucu sayesinde milin şaftla optimum uyumu.



### GLIDE & FIX

Optimal geometri çenenin giriş üzerinde kolayca ve hızlı kaydırılmasına izin verir.



### ARMLOCK

Çapraz kancalar çenenin kayar parça içine asılmasında azami denge sağlar.



## Yedek parça

Ürün No.	Ürün adı
614135	Mekanik mil
1-90-S	3 çekirme kolu (set)
30-10-T	Gövde

## Aksesuarlar

Ürün No.	Ürün adı
K-600-014	KUKKO Milleri için, "6'sı 1 arada" değiştirilebilir Mil Uç Geçme Parçaları

## Beraber

Ürün No.	Ürün adı
13-TP-1	3 parçalı ayırıcı (set)



## De içinde bulunur

Ürün No.	Ürün adı
K-2030-10	2 ve 3 kollu üniversal çekirme seti
30-20-T	Çekirme - Sanayi için - BASIC

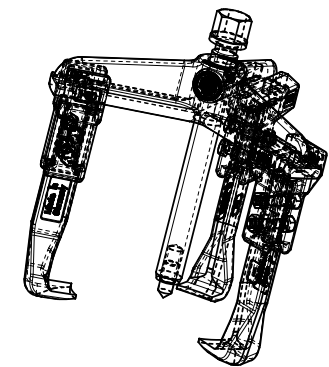
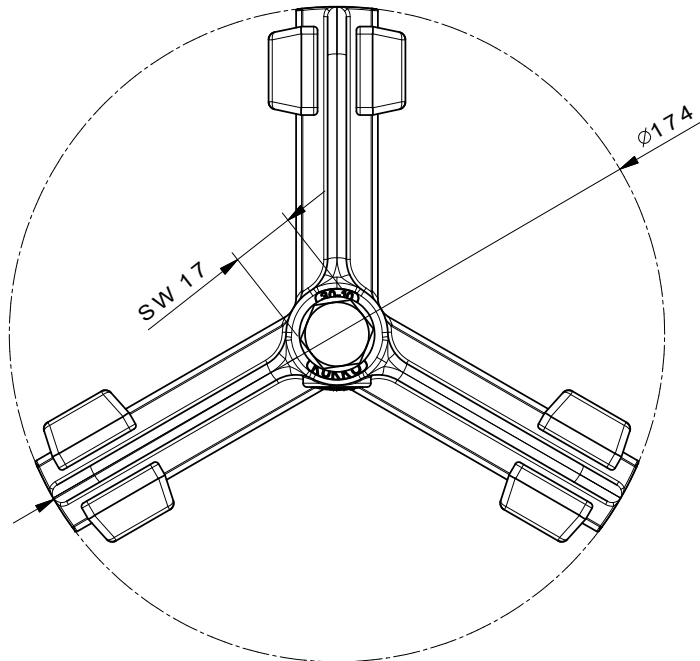
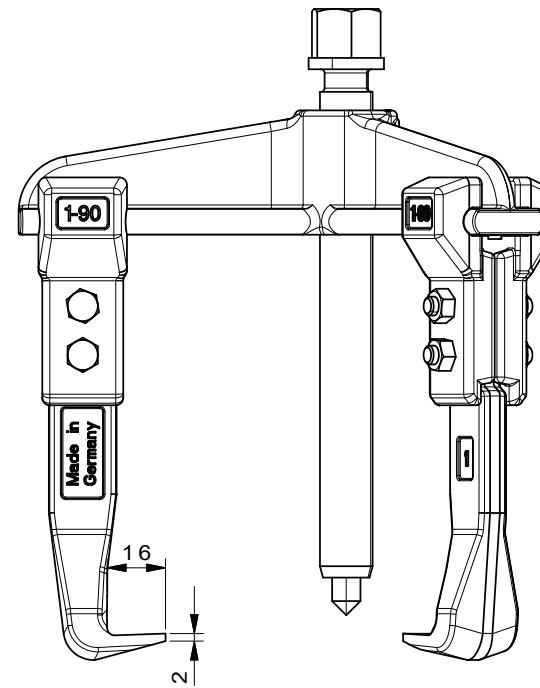
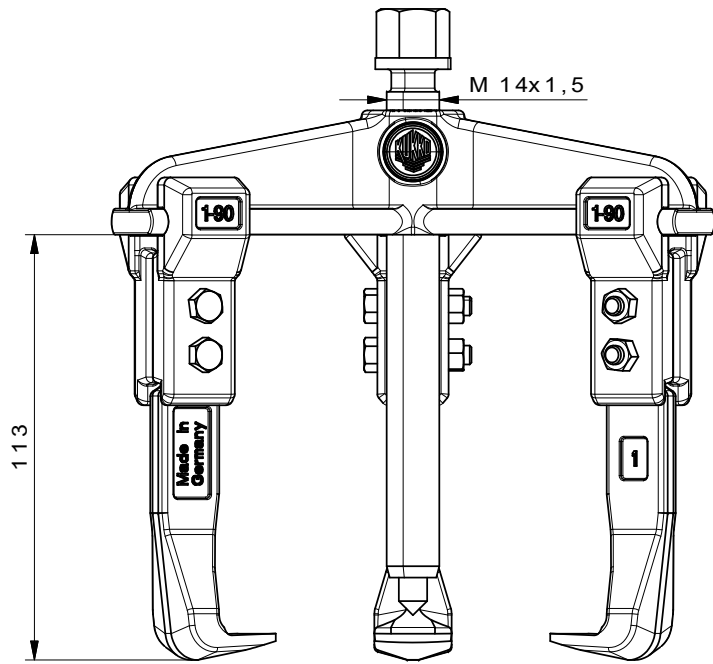

 <b>Kleinbongartz &amp; Kaiser oHG</b> Werkzeugfabrik Hilden - Germany	Dokumentname: 30-10_3-Arm-Universal_Abzieher	Toleranz: DIN ISO 2768-m
	Dokumentbeschreibung: Baugruppe	Material: Hoch legierter Werkzeugstahl / High alloy tool steel
Erstellt von: Breidenbach	Erstellungsdatum: 30/03/2015	Maßstab: 1:1
Teilbeschreibung: 3-Arm-Universal_Abzieher/ Universal 3-jaw puller with narrow jaws		Wärmebehandlung / Härte: vergüteter Stahl/ tempered steel
Oberflächenbehandlung:		Schutzvermerk ISO 16016 beachten
Artikelnummer / ZNR.: 30-10	Dokumentversion: -	