



Productnaam \*

## 3-armige universele trekker met dunne trekhaken





Voor het trekken van lagers, tandwielen, schijven enz voor nauwe tussenruimtes

Art nr. 30-2-S

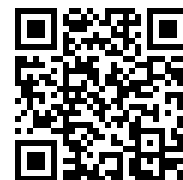
Serie 30-S

EAN 4021176727856



	Technisch kenmerk	Metrisch	Imperial
	Spanwijdte, uitwendig	35 - 160 mm	1 3/8 - 6 3/8 inch
	Spandiepte	150 mm	5 7/8 inch
	Spanwijdte inwendig	100 - 220 mm	3 7/8 - 8 5/8 inch
	Buitenzeskant	22 mm	
max.	Maximaal toegestane belasting	5 t	5.5 US t
	Max. aandraaimoment	120 Nm	88.5 ft lb
	Gewicht	3.78 kg	
	Ruimte beneden	4 mm	3/16 inch
	Raum nebendran	19 mm	3/4 inch
	Aantal haken	3	3



## Technologieën



### GLIDE & FIX

De geoptimaliseerde geometrie waarborgt dat de trekhaken makkelijk en snel verschoven kunnen worden op de traverse.



### ARMLOCK

De kruishaken waarborgen maximale stabiliteit voor de ophanging van de trekhaken in het glijstuk.



### SWITCH

Optimale aanpassing van de spil aan de as dankzij de dubbele spilkop.



## Onderdeel

<b>Art nr.</b>	<b>Productnaam</b>
621220	Mechanische spindels.
2-151-S	3 dunne trekhaken (set)
30-2-T	Drie-armige brug

## Toebehoren

<b>Art nr.</b>	<b>Productnaam</b>
2-301-S	3 dunne trekhaken (set)
2-V-150-S	3 trekhaak verlengstukken (set)
K-600-025	Wisseldrukstukken set voor KUKKO spindels

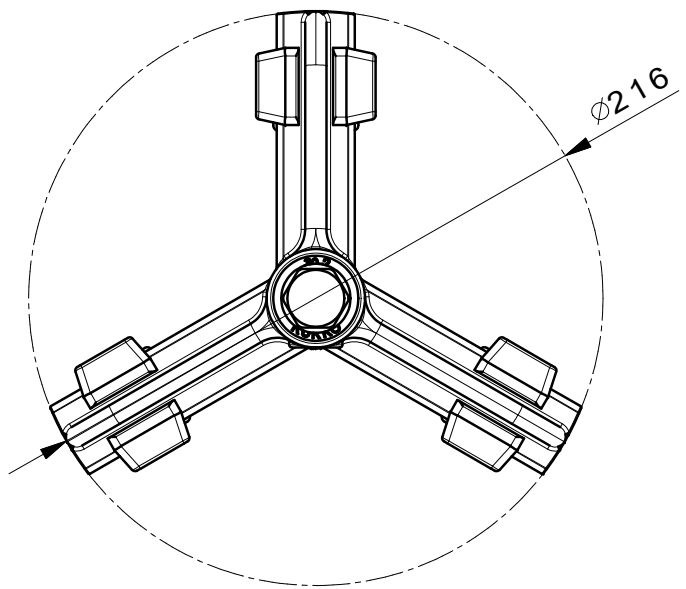
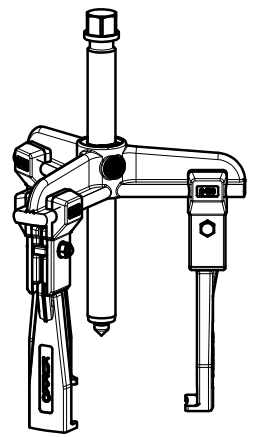
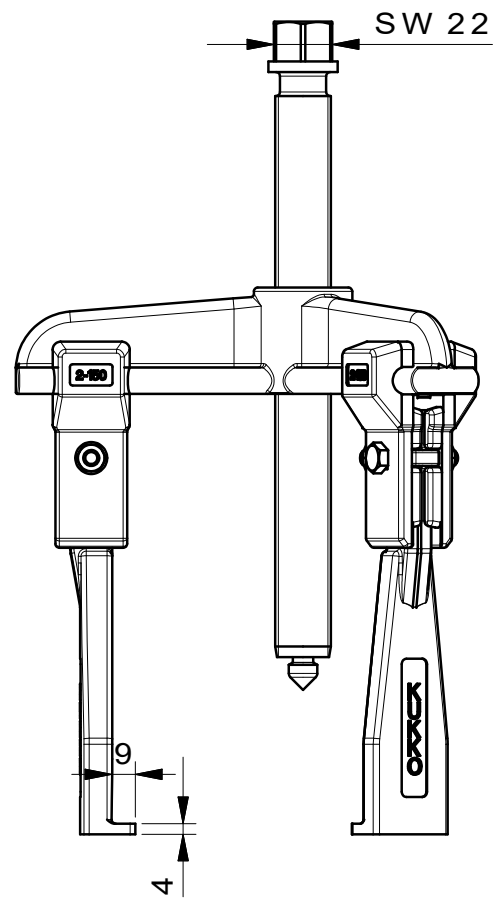
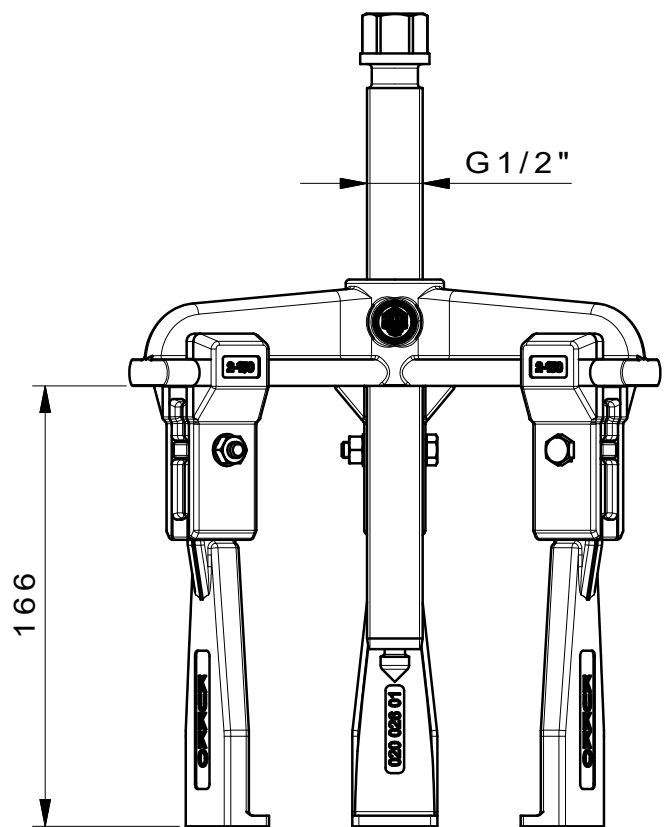

 <b>Kleinbongartz &amp; Kaiser oHG</b> Werkzeugfabrik Hilden - Germany	Dokumentname: 30-2-S_Abzieher	Toleranz: DIN ISO 2768-m
	Dokumentbeschreibung: Baugruppe	Material: Hoch legierter Werkzeugstahl / High alloy tool steel
Erstellt von: Breidenbach	Erstellungsdatum: 20/06/2017	Maßstab: 1:2
Teilbeschreibung: 3-armiger Universal Abzieher mit schmalen Abzughaken/ Universal 3-jaw puller with narrow jaws		Wärmebehandlung / Härte: vergüteter Stahl/ tempered steel
Artikelnummer / ZNR.: 30-2-S	Dokumentversion: -	Schutzvermerk ISO 16016 beachten
Oberflächenbehandlung:		