



Ürün adı \*

## Dar çekirme kollarına sahip 3 kollu üniversal çekirme

Dar ve erişilmesi zor alanlarda yatakların, dişlilerin ve rondelaların çekirilmesi için.

Ürün No. 30-2-S

Seriler 30-S

EAN 4021176727856



	<b>Teknik özellik</b>	<b>Metrik</b>	<b>İmparatorluk</b>
	Açılma genişliği	35 - 160 mm	1 3/8 - 6 3/8 inch
	Derinlik	150 mm	5 7/8 inch
	İç çekirme açılma genişliği	100 - 220 mm	3 7/8 - 8 5/8 inch
	Altıköşe geçme (erkek)	22 mm	
max.	İzin verilen maksimum yük	5 t	5.5 US t
	Maks. tork	120 Nm	88.5 ft lb
	Ağırlık	3.78 kg	
	Raum unterhalb	4 mm	3/16 inch
	Raum nebendran	19 mm	3/4 inch
	Çene sayısı	3	3



## Teknolojiler



### GLIDE & FIX

Optimal geometri çenenin giriş üzerinde kolayca ve hızlı kaydırılmasına izin verir.



### ARMLOCK

Çapraz kancalar çenenin kayar parça içine asılmasında azami denge sağlar.



### SWITCH

İki taraflı mil ucu sayesinde milin şaftla optimum uyumu.



## Yedek parça

Ürün No.	Ürün adı
621220	Mekanik mil
2-151-S	3 dar çektirme kolu (çift)
30-2-T	3 kollu çektirme gövdesi

## Aksesuarlar

Ürün No.	Ürün adı
2-301-S	3 dar çektirme kolu (çift)
2-V-150-S	3 çektirme kolu uzatması (set)
K-600-025	KUKKO Milleri için, "6'sı 1 arada" değiştirilebilir Mil Uç Geçme Parçaları

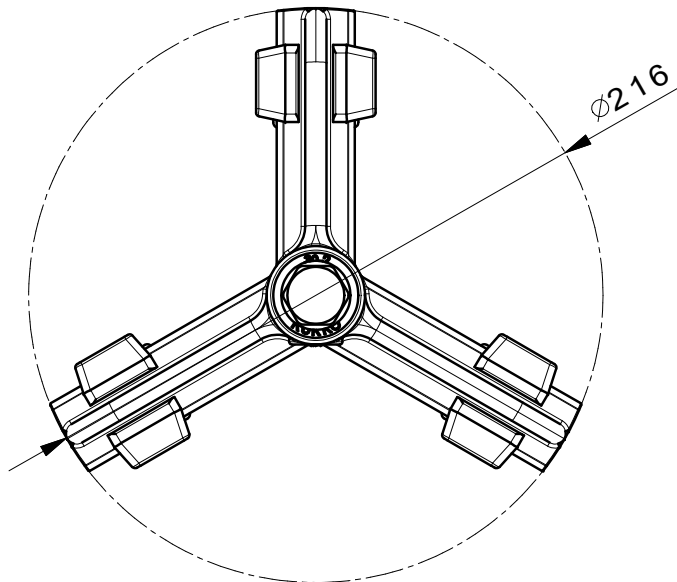
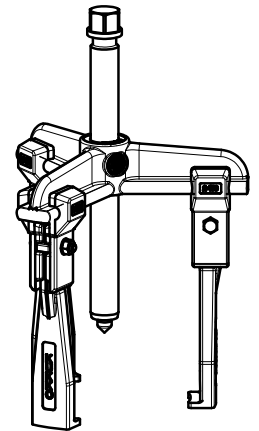
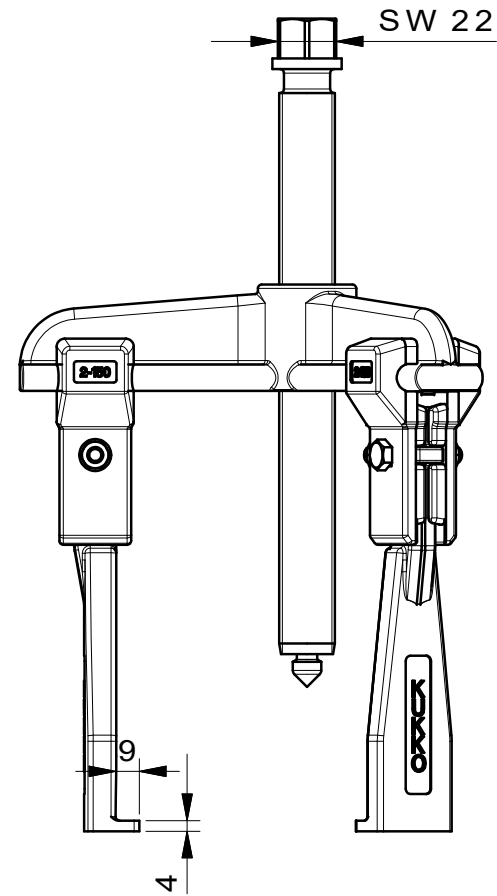
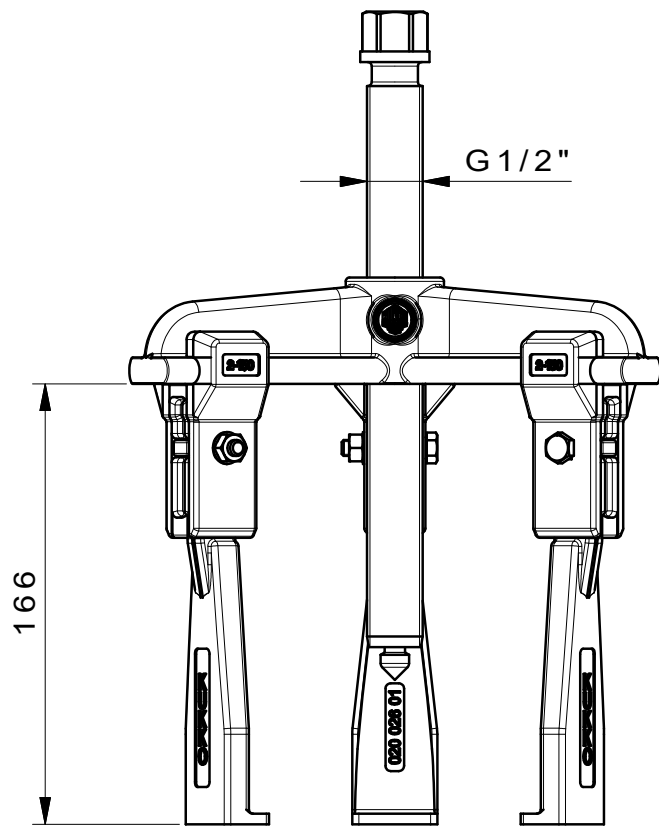

 <b>Kleinbongartz &amp; Kaiser oHG</b> Werkzeugfabrik Hilden - Germany	Dokumentname: 30-2-S_Abzieher	Toleranz: DIN ISO 2768-m
	Dokumentbeschreibung: Baugruppe	Material: Hoch legierter Werkzeugstahl / High alloy tool steel
Erstellt von: Breidenbach	Erstellungsdatum: 20/06/2017	Maßstab: 1:2
Teilbeschreibung: 3-armiger Universal Abzieher mit schmalen Abzughaken/ Universal 3-jaw puller with narrow jaws		Wärmebehandlung / Härte: vergüteter Stahl/ tempered steel
Artikelnummer / ZNR.: 30-2-S	Dokumentversion: -	Schutzvermerk ISO 16016 beachten
Oberflächenbehandlung:		