



产品名称 *

通用三爪拉马带长拉马爪









用于在紧密或难以接近的空间内拆卸轴承、齿轮、圆盘等

编号 30-2-S

系列 30-S

EAN 4021176727856



技术规格	公制	英制
 跨度	35 - 160 mm	1 3/8 - 6 3/8 inch
 深度	150 mm	5 7/8 inch
 内部使用扩展	100 - 220 mm	3 7/8 - 8 5/8 inch
 六角驱动 (公)	22 mm	
max. 最大负载	5 t	5.5 US t
max. 最大扭矩	120 Nm	88.5 ft lb
 重量	3.78 kg	
 下方空间	4 mm	3/16 inch
 邻近空间	19 mm	3/4 inch
 拉马爪数量	3	3



技术



滑动&固定

优化的几何形状保证拉马爪能在横梁上轻松快速移动。



臂锁

十字爪最大程度地保证了滑块中拉马爪悬挂的稳定性。



开关

通过两边的轴尖来调整优化主轴的位置。



配件

编号	产品名称
621220	机械压力主轴。
2-151-S	三个细拉马爪（套）
30-2-T	三爪横杆

附件

编号	产品名称
2-301-S	三个细拉马爪（套）
2-V-150-S	三个拉马爪延长杆（套）
K-600-025	KUKKO 压紧轴的可更换承压件套件

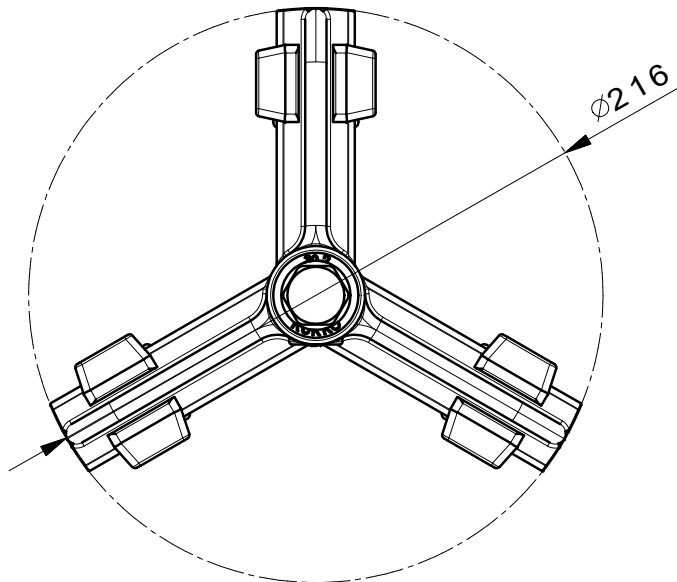
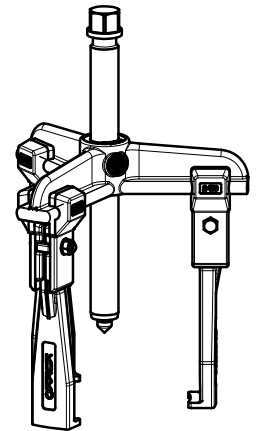
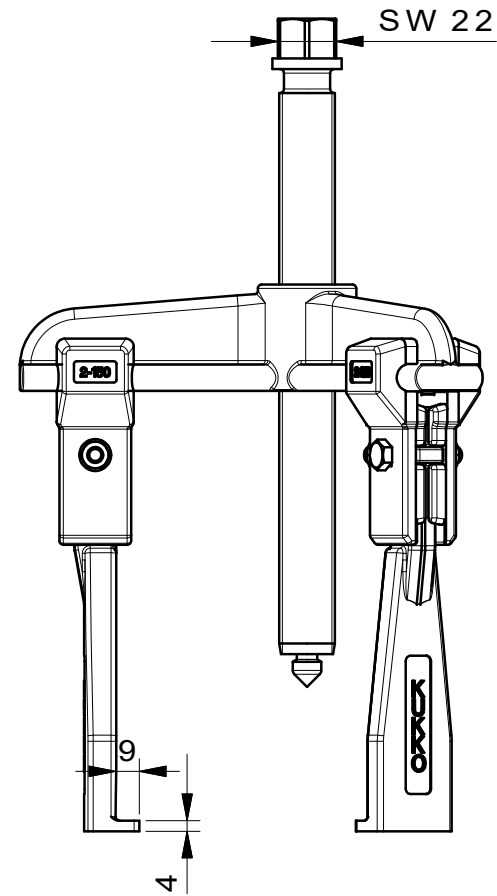
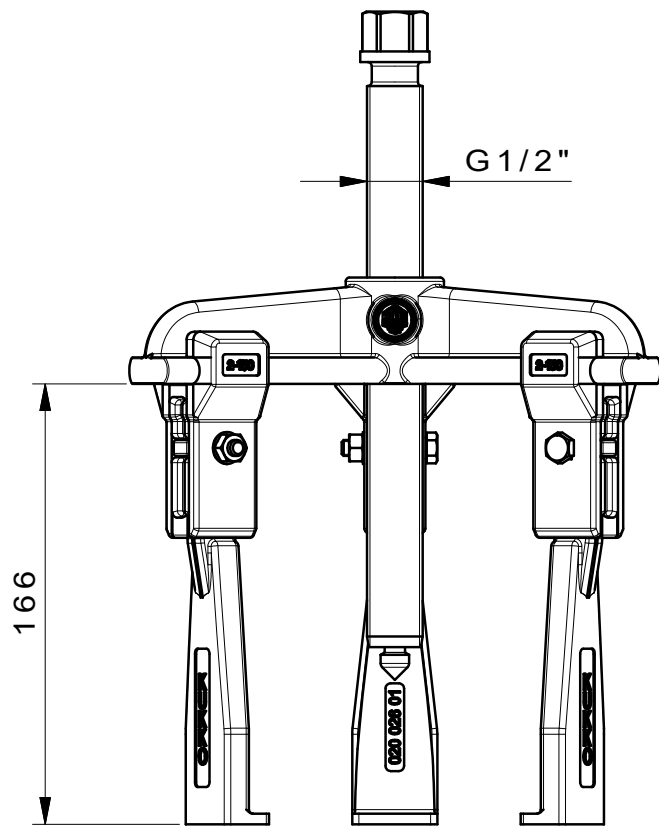

 Kleinbongartz & Kaiser oHG Werkzeugfabrik Hilden - Germany	Dokumentname: 30-2-S_Abzieher	Toleranz: DIN ISO 2768-m
	Dokumentbeschreibung: Baugruppe	Material: Hoch legierter Werkzeugstahl / High alloy tool steel
Erstellt von: Breidenbach	Erstellungsdatum: 20/06/2017	Maßstab: 1:2
Teilbeschreibung: 3-armiger Universal Abzieher mit schmalen Abzughaken/ Universal 3-jaw puller with narrow jaws		Wärmebehandlung / Härte: vergüteter Stahl/ tempered steel Oberflächenbehandlung:
Artikelnummer / ZNR.: 30-2-S	Dokumentversion: -	Schutzvermerk ISO 16016 beachten