



Product name *

Universal 3-jaw puller with narrow jaws

For removing bearings, gears, discs, etc. for tight or difficult-to-access spaces.

Art. No. 30-20-S

Series 30-S

EAN 4021176727931



	Technical attribute	Metric	Imperial
	Spread	35 - 200 mm	1 3/8 - 7 7/8 inch
	Depth	150 mm	5 7/8 inch
	Spread used internal	100 - 260 mm	3 7/8 - 10 1/4 inch
	Hexagon drive (male)	22 mm	
	Maximum load	5 t	5.5 US t
	Maximum torque	120 Nm	88.5 ft lb
	Weight	4.08 kg	
	Space below	4 mm	3/16 inch
	Space next to it	19 mm	3/4 inch
	Number of jaws	3	3



Technologies



GLIDE & FIX

The improved geometry guarantees quick and easy movement of the jaws on the cross-beam.



ARMLOCK

The cross-legged jaws guarantee maximum stability for suspending the jaws in the slider.



SWITCH

A two-sided spindle tip provides optimal adjustment of the spindle to the shaft.



Spare part

Art. No.	Product name
621220	Mechanical pressure spindle.
2-151-S	3 narrow jaws (set)
30-20-T3	3-jaw cross bar

Accessories

Art. No.	Product name
2-151-S	3 narrow jaws (set)
2-301-S	3 narrow jaws (set)
2-V-150-S	3 jaw extensions (set)
K-600-025	Set of interchangeable pressure pads for KUKKO pressure screws

Also included in

Art. No.	Product name
WT-008	Puller product range - commercial vehicles - BASIC
K-2030-20-S	Set of two- and three-arm pullers with narrow jaws

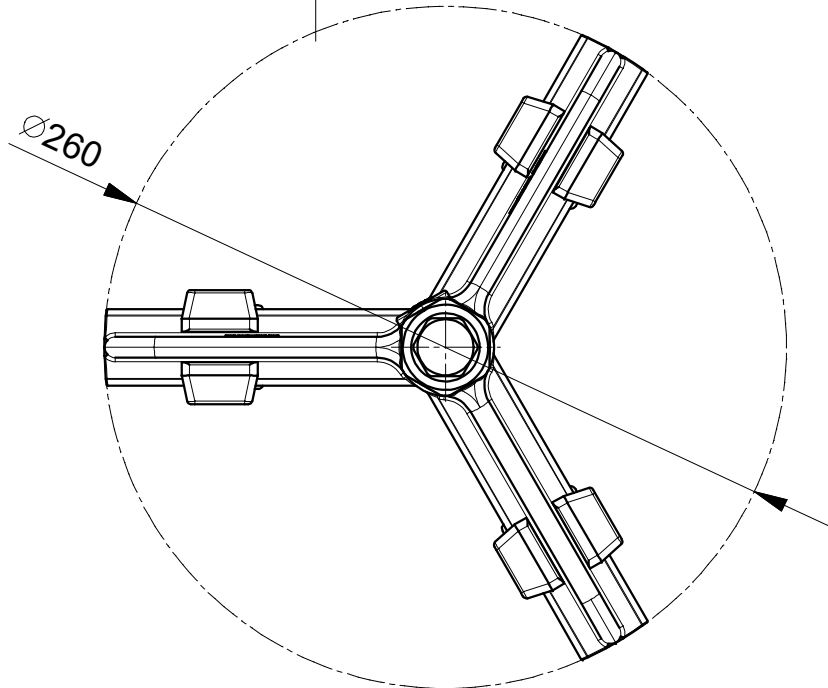
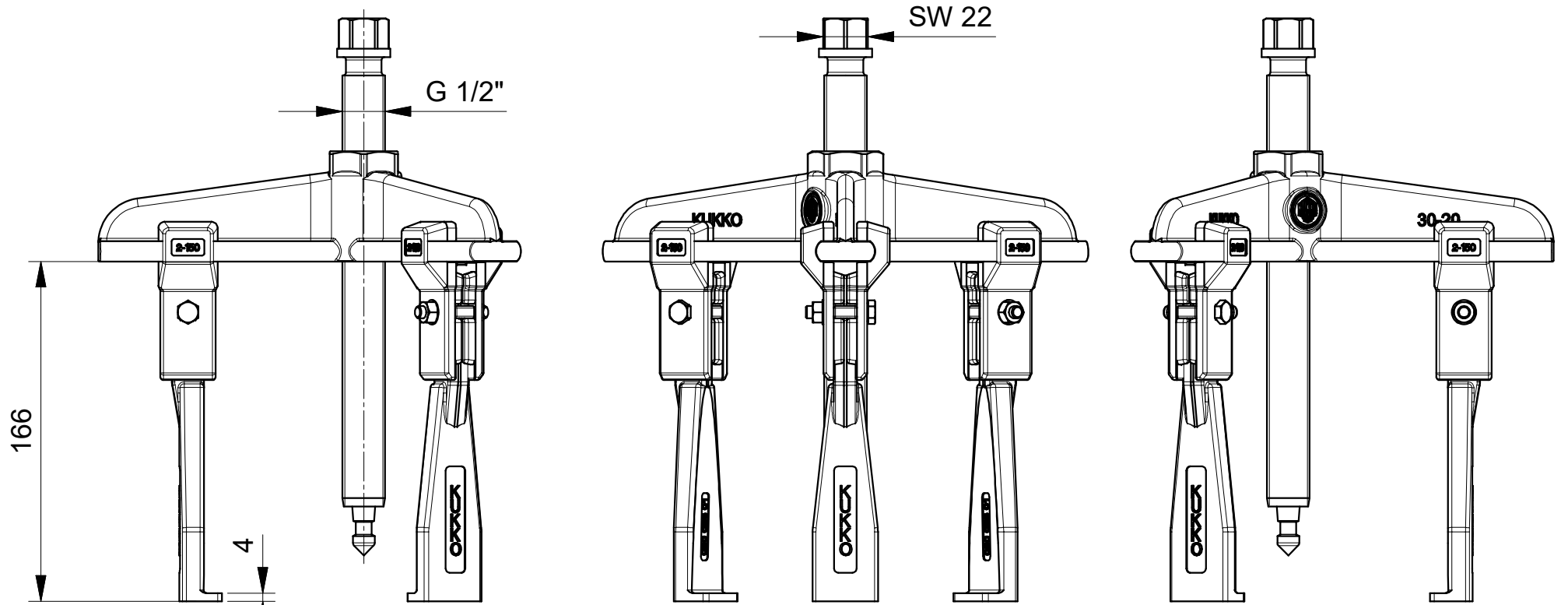

 Kleinbongartz & Kaiser oHG Werkzeugfabrik Hilden - Germany	Dokumentname: 30-20-S_2-Armiger-Universal Abzieher	Toleranz: DIN ISO 2768-m
	Dokumentbeschreibung: Baugruppe	Material: Hoch legierter Werkzeugstahl / High alloy tool steel
	Erstellt von: Breidenbach	Erstellungsdatum: 02/05/2018
Teilbeschreibung: 3-armiger Universal Abzieher mit schmalen Abzughaken/ Universal 3-jaw puller with narrow jaws		Wärmebehandlung / Härte: vergüteter Stahl/ tempered steel
Artikelnummer / ZNR.: 30-20-S		Oberflächenbehandlung: Schutzvermerk ISO 16016 beachten