



Nome del prodotto

Estrattore universale a 2 bracci con griffe autocentranti









Per l'estrazione di cuscinetti, ingranaggi, pulegge ecc.

Num. art. 44-1

Serie 44

EAN 4021176016028



	Attributo tecnico	Metrico	Imperiale
	Ampiezza di serraggio esterna	12 - 100 mm	1/2 - 3 7/8 inch
	Profondità di serraggio	100 mm	3 7/8 inch
	Esagono esterno	13 mm	
max.	Carico massimo consentito	3 t	3 US t
	Coppia massima	50 Nm	6.5 ft lb
	Peso	0.525 kg	
	Spazio sotto	7 mm	1/4 inch
	Spazio adiacente	20 mm	3/4 inch
	Numero delle griffe	2	2



Tecnologie



SWITCH

Adattamento ottimale dei mandrini all'albero grazie alla punta bilaterale dei mandrini.



AUTOGRIP

I ganci di estrazione vengono serrati e centrati automaticamente.



Pezzo di ricambio

Num. art.	Nome del prodotto
44-1-T	Traversa
44-1-100-P	2 griffe (paio)
44-1-206	Traversa con boccola e vite di pressione
612130	Vite di pressione meccanica.

Acessori

Num. art.	Nome del prodotto
K-600-014	Set di pressori intercambiabili per viti di pressione KUKKO

é parte di

Num. art.	Nome del prodotto
EVLW-2-INDUSTRIE	Display di vendita Industria
WT-1-INDUSTRIE	Assortimento estrattori - Industria
EVLW-INDUSTRIE BASIC	Display di vendita Industria

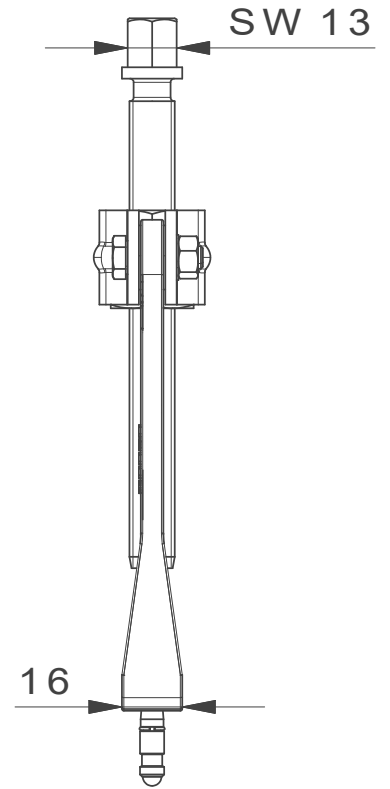
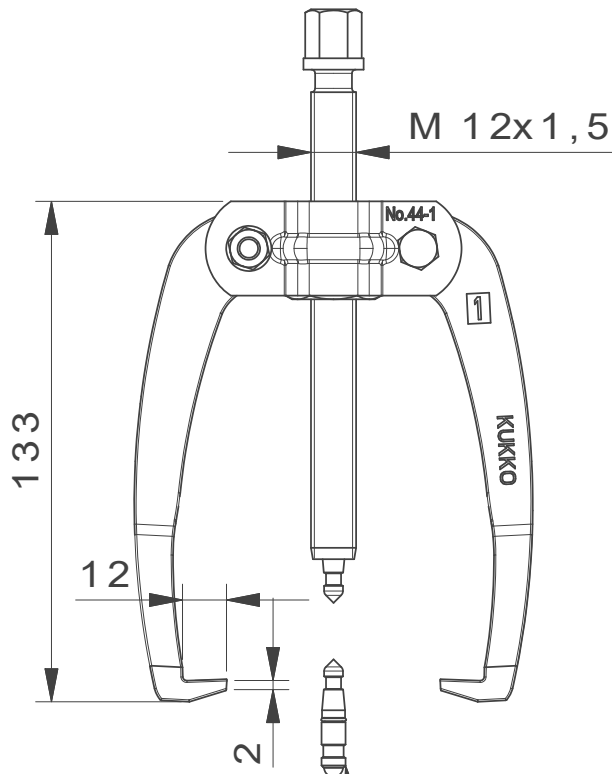

Mit Wechseldruckstück

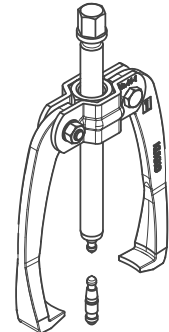
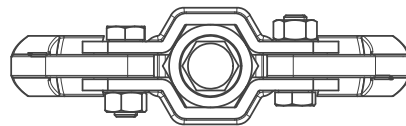

**Kleinbongartz
& Kaiser
oHG**
Werkzeugfabrik
Hilden - Germany

Dokumentname:
44-1_2-armiger Universal Abzieher

Toleranz:
DIN ISO 2768-m

Dokumentbeschreibung:
Baugruppe

Material:
Hoch legierter Werkzeugstahl /
High alloy tool steel

Erstellt von:
Breidenbach

Erstellungsdatum:
02/03/2016

Maßstab:
1:2

Teilbeschreibung:

2-armiger Universal Abzieher/
Universal 2-jaw puller with self-centering jaws

Wärmebehandlung / Härte:
vergüteter Stahl/ tempered steel

Oberflächenbehandlung:

Artikelnummer / ZNR.:
44-1

Dokumentversion:
-

Schutzvermerk
ISO 16016
beachten