



Productnaam

2-armige universele trekker met zelfcentrerende trekhaken

Voor het trekken van lagers, tandwielen, schijven enz

Art nr. 44-4

Serie 44

EAN 4021176016363



	Technisch kenmerk	Metrisch	Imperial
	Spanwijdte, uitwendig	23 - 250 mm	7/8 - 9 7/8 inch
	Spandiepte	200 mm	7 7/8 inch
	Buitenzeskant	24 mm	
max.	Maximaal toegestane belasting	7 t	7.5 US t
	Max. aandraaimoment	190 Nm	140 ft lb
	Gewicht	3.28 kg	
	Ruimte beneden	12 mm	1/2 inch
	Raum nebendran	17 mm	3/4 inch
	Aantal haken	2	2



Technologieën



SWITCH

Optimale aanpassing van de spil aan de as dankzij de dubbele spilkop.



AUTOGRIP

De trekhaken worden automatisch gespannen en gecentreerd.



Onderdeel

Art nr.	Productnaam
44-4-T	Brug
44-4-200-P	2 trekhaken (paar)
44-4-206	Draadbus voor brug met spindel
623260	Mechanische spindels.

Toebehoren

Art nr.	Productnaam
K-600-025	Wisseldrukstukkenet voor KUKKO spindels

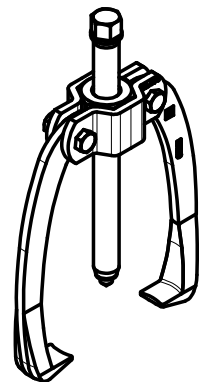
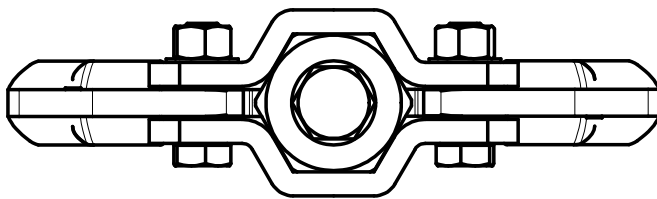
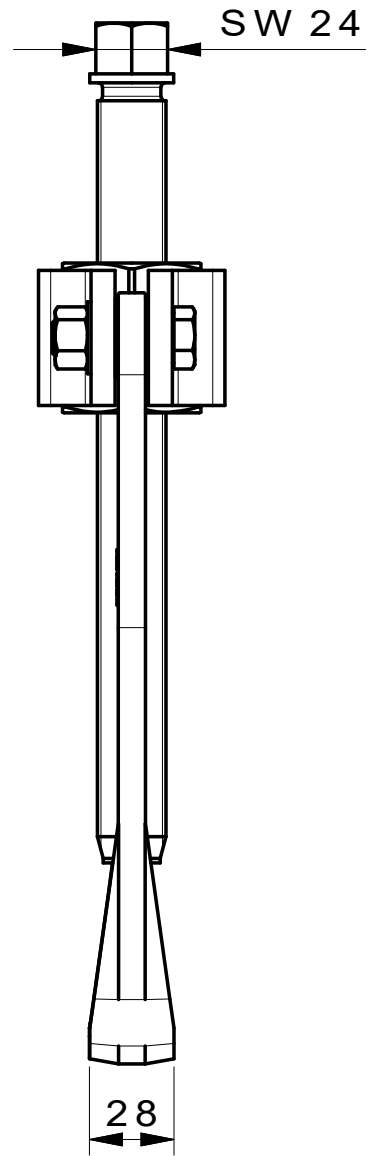
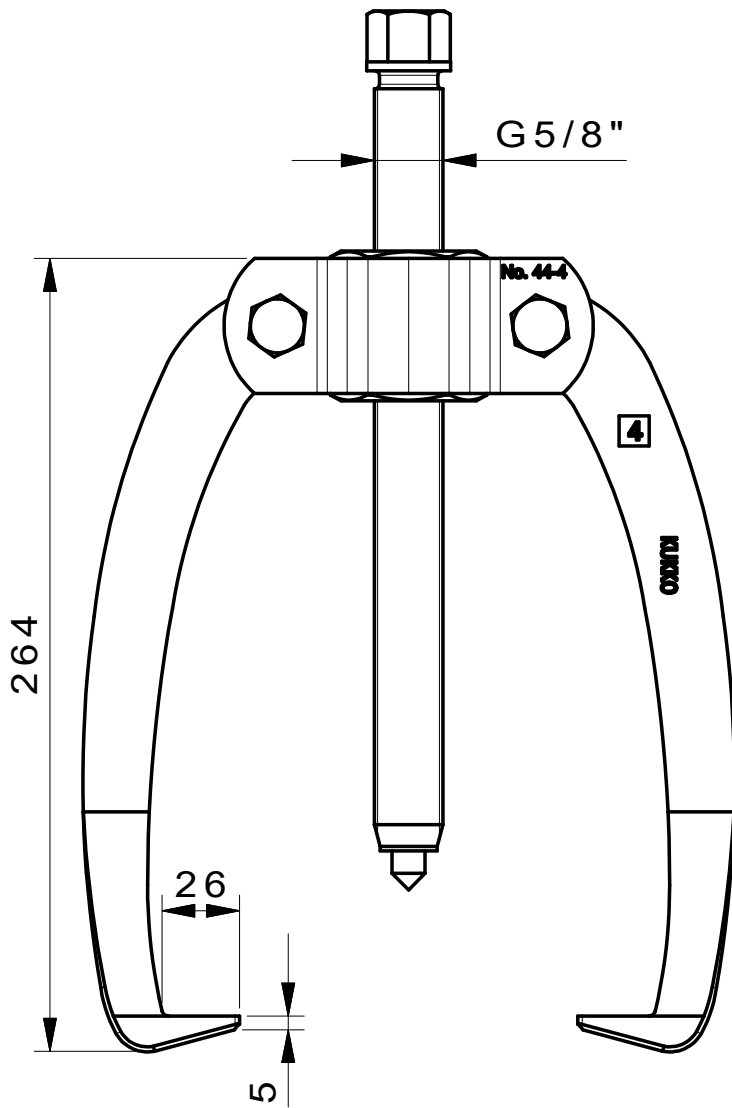

**Kleinbongartz
& Kaiser
oHG**
Werkzeugfabrik
Hilden - Germany

Dokumentname:
44-4_2-armiger Universal Abzieher

Toleranz:
DIN ISO 2768-m

Dokumentbeschreibung:
Baugruppe

Material:
Hoch legierter Werkzeugstahl /
High alloy tool steel

Erstellt von:
K.Breidenbach

Erstellungsdatum:
08/04/2016

Maßstab:
1:2.5

Teilbeschreibung:

2-armiger Universal Abzieher mit selbstzentrierenden Abzughaken/
Universal 2-jaw puller with self-centering jaws

Vergütung:
vergüteter Stahl/ tempered steel

Oberflächenbehandlung:.

Teil Nr.:
44-4

Schutzvermerk
ISO 16016
beachten