



Ürün adı

## Kendinden merkezlenen çekirme kancasına sahip 2 kollu universal çekirme









Yatakları, dişlileri, rondelaları vb. çıkarmak için.

Ürün No. 44-4

Seriler 44

EAN 4021176016363



	<b>Teknik özellik</b>	<b>Metrik</b>	<b>İmparatorluk</b>
	Açılma genişliği	23 - 250 mm	7/8 - 9 7/8 inch
	Derinlik	200 mm	7 7/8 inch
	Altıköşe geçme (erkek)	24 mm	
max.	İzin verilen maksimum yük	7 t	7.5 US t
	Maks. tork	190 Nm	140 ft lb
	Ağırlık	3.28 kg	
	Raum unterhalb	12 mm	1/2 inch
	Raum nebendran	17 mm	3/4 inch
	Çene sayısı	2	2



## Teknolojiler



### SWITCH

İki taraflı mil ucu sayesinde milin şaftla optimum uyumu.



### AUTOGRIP

Çeneler otomatik olarak gerilir ve ortalanır.



## Yedek parça

Ürün No.	Ürün adı
44-4-T	Gövde
44-4-200-P	2 çekirme kolu (çift)
44-4-206	Gövde iç burcu, miliyle
623260	Mekanik mil

## Aksesuarlar

Ürün No.	Ürün adı
K-600-025	KUKKO Milleri için, "6'sı 1 arada" değiştirilebilir Mil Uç Geçme Parçaları

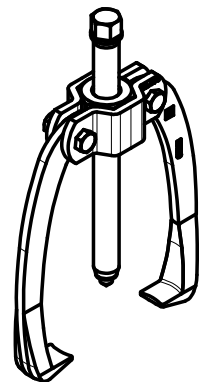
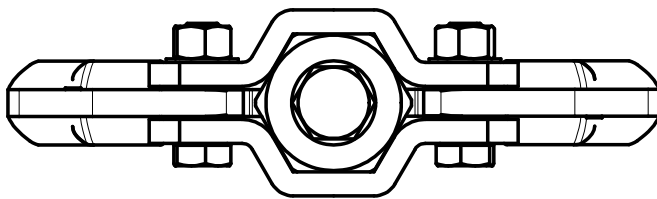
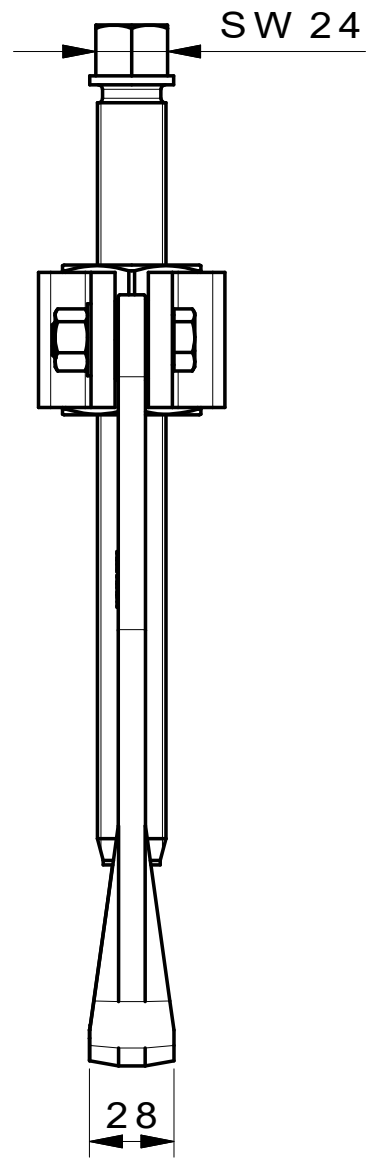
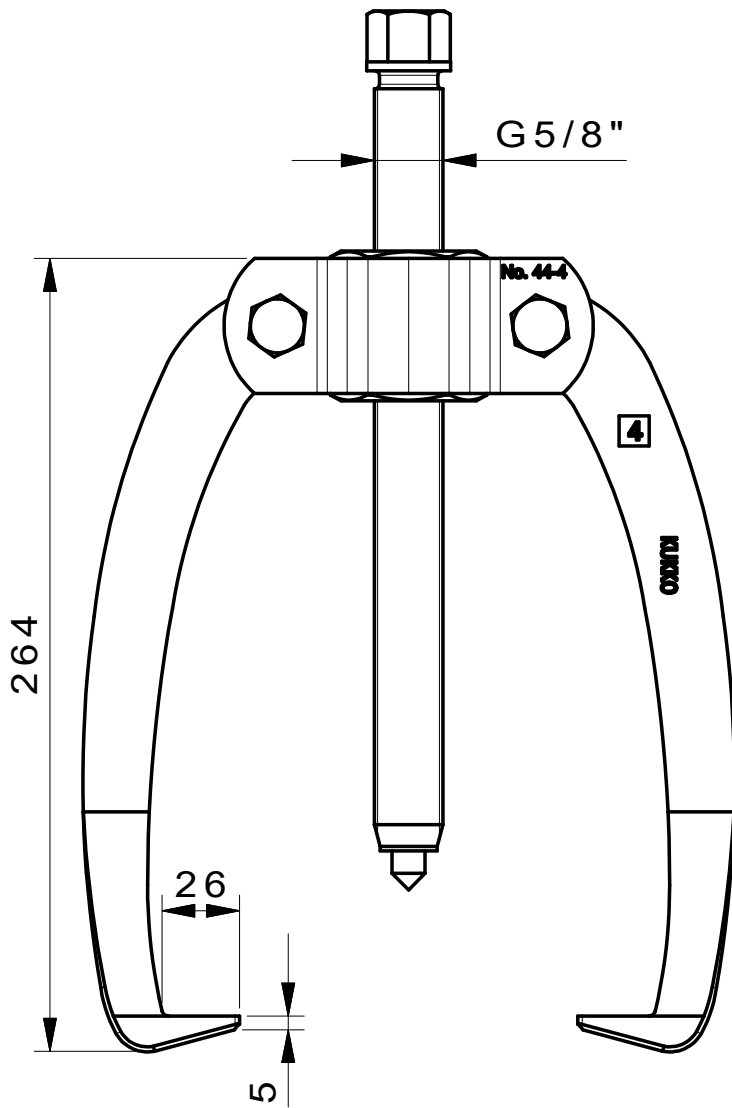

**Kleinbongartz  
& Kaiser  
oHG**  
Werkzeugfabrik  
Hilden - Germany

Dokumentname:  
44-4\_2-armiger Universal Abzieher

Toleranz:  
DIN ISO 2768-m

Dokumentbeschreibung:  
Baugruppe

Material:  
Hoch legierter Werkzeugstahl /  
High alloy tool steel

Erstellt von:  
K.Breidenbach

Erstellungsdatum:  
08/04/2016

Maßstab:  
1:2.5

Teilbeschreibung:

2-armiger Universal Abzieher mit selbstzentrierenden Abzughaken/  
Universal 2-jaw puller with self-centering jaws

Vergütung:  
vergüteter Stahl/ tempered steel

Oberflächenbehandlung:.

Teil Nr.:  
44-4

Schutzvermerk  
ISO 16016  
beachten