



Nome del prodotto

Estrattore universale a 2 bracci con Autogrip







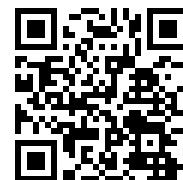

Per l'estrazione di cuscinetti, ingranaggi, pulegge, ecc. per spazi ristretti e difficili da raggiungere.

Num. art. 482-3

Serie 482

EAN 4021176479939



	Attributo tecnico	Metrico	Imperiale
	Ampiezza di serraggio esterna	20 - 150 mm	3/4 - 5 7/8 inch
	Profondità di serraggio	150 mm	5 7/8 inch
	Esagono esterno	10 mm	
max.	Carico massimo consentito	2,5 t	2.5 US t
	Coppia massima	35 Nm	25.5 ft lb
	Peso	0.875 kg	
	Spazio sotto	8 mm	3/8 inch
	Spazio adiacente	17 mm	3/4 inch
	Numero delle griffe	2	2



Tecnologie



SWITCH

Adattamento ottimale dei mandrini all'albero grazie alla punta bilaterale dei mandrini.



AUTOGRIP

I ganci di estrazione vengono serrati e centrati automaticamente.



TECNOLOGIA AUTO-SNAP



Pezzo di ricambio

Num. art.	Nome del prodotto
482-3-206	Vite di pressione meccanica con boccola e molla
482-3-T	Traversa
482-3-150-P	2 griffe (paio)
612200	Vite di pressione meccanica.

Acessori

Num. art.	Nome del prodotto
K-600-014	Set di pressori intercambiabili per viti di pressione KUKKO

é parte di

Num. art.	Nome del prodotto
K-482	Estrattori universali a 2 bracci con Auto-Snap in set
29-B	Set di estrattori universali in TANOS-Systainer®



é pezzo di ricambio di

Num. art.

Nome del prodotto

K-482

Estrattori universali a 2 bracci con Auto-Snap in set

29-B

Set di estrattori universali in TANOS-Systainer®

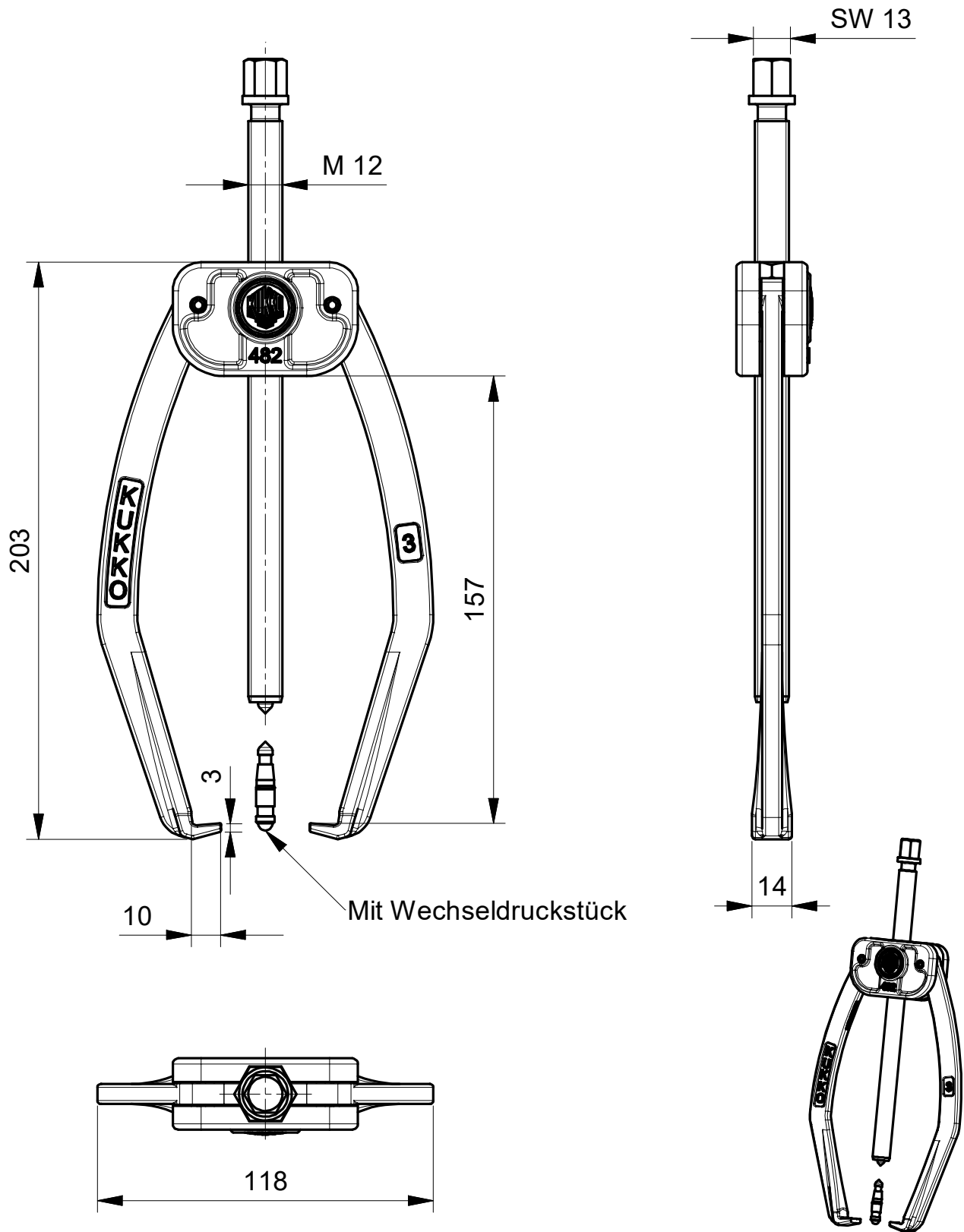

 <p>Kleinbongartz & Kaiser oHG Werkzeugfabrik Hilden - Germany</p>	Dokumentname: 482-3_2-armiger Universal Abzieher		Toleranz: DIN ISO 2768-m
	Dokumentbeschreibung: Baugruppe		Material: Hoch legierter Werkzeugstahl / High alloy tool steel
	Erstellt von: Breidenbach	Erstellungsdatum: 21/01/2019	Maßstab: 1:2
Teilbeschreibung: 2-armiger Universal Abzieher mit Autogrip/ Universal 2-jaw pullers with Auto-Snap		Wärmebehandlung / Härte: vergüteter Stahl/ tempered steel	
		Oberflächenbehandlung: -	
Artikelnummer / ZNR.: 482-3	Dokumentversion: -	Schutzvermerk ISO 16016 beachten	