



Nome do produto

Cortador de porcas mecânico de lâmina dupla

Cortador de porcas de lâmina dupla com efeito explosivo duplo para porcas fixas indissociáveis das categorias 5, 6 e 8.









Artigo Nº 54-2

Série 54

EAN 4021176170614



	Características	Métrico	Polegada
	Tamanho = para porcas	10 - 27 mm	3/8 - 1 1/16 inch
	Amplitude da lâmina de cinzel (mm)	14 mm	
	Comprimento sem eixo de compressão (mm)	109 mm	
	Hexágono externo	17 mm	
	Peso	0.48 kg	
	Amplitude da lâmina de cinzel (polegadas)		5/8 inch
	Comprimento sem eixo de compressão (polegadas)		4 5/16 inch



Tecnologias



PULLBACK

Retração automática do formão separador através do parafuso atuador.



Peça de substituição

Artigo Nº**Nome do produto**

54-2-M

Novo cinzel para cortador de porcas

Faz parte de

Artigo Nº**Nome do produto**

WT-005

Gama de extratores - Indústria automóvel

K-54-B

Kit de cortador de porcas mecânico

EVLW-2-KFZ

Parede de vendas automóvel

EVLW-2-NFZ

Parede de vendas automóvel/ veículos comerciais/ máquinas agrícolas

é uma peça de substituição de

Artigo Nº**Nome do produto**

WT-005

Gama de extratores - Indústria automóvel



Está também incluído em

Artigo N°

Nome do produto

WT-005

Gama de extratores - Indústria automóvel

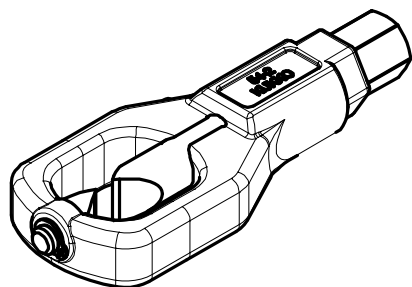
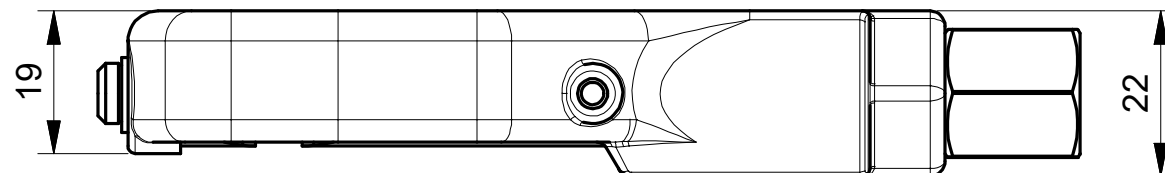
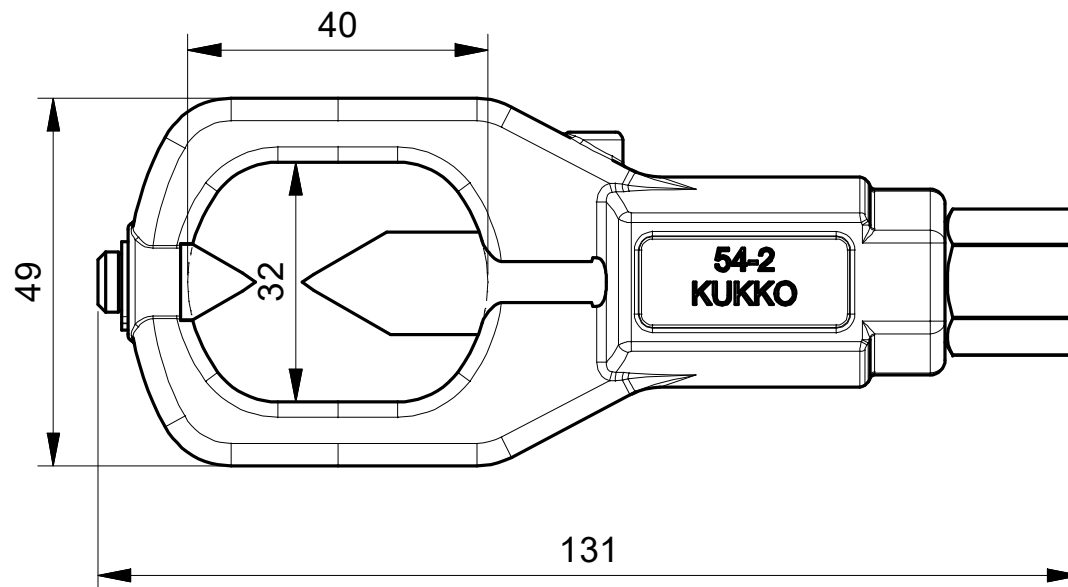
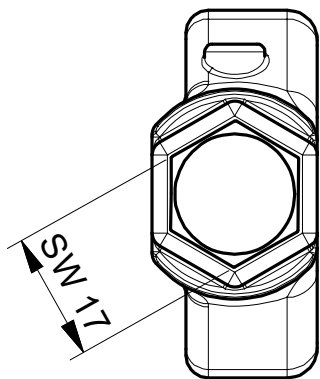

 Kleinbongartz & Kaiser oHG Werkzeugfabrik Hilden - Germany	Dokumentname:		Toleranz: DIN ISO 2768-m	
	Dokumentbeschreibung:		Material:	
	Erstellt von: Schultes	Erstellungsdatum: 04/10/2019	Maßstab: 1:1	
Teilbeschreibung: Zweischneidiger mechanischer Mutternsprenger			Wärmebehandlung / Härte:	
			Oberflächenbehandlung:	
Artikelnummer / ZNR.: 54-2	Dokumentversion: -		Schutzvermerk ISO 16016 beachten	