



Ürün adı

İki kenarlı, mekanik somun ayırıcı







5, 6 ve 8 sınıfı uçları ayrılmaz şekilde sabitlenmiş somunlar için çift patlatma etkisine sahip çift kenarlı somun ayırıcılar.

Ürün No. 54-2

Seriler 54

EAN 4021176170614



	Teknik özellik	Metrik	Imparatorluk
	Ebat = somunlar için	10 - 27 mm	3/8 - 1 1/16 inch
	Keskinin kesme ağız genişliği	14 mm	
	Mil hariç uzunluk (mm)	109 mm	
	Altıköşe geçme (erkek)	17 mm	
	Ağırlık	0.48 kg	
	Keskinin kesme ağız genişliği (inç)		5/8 inch
	Mil hariç uzunluk (inç)		4 5/16 inch



Teknolojiler



PULLBACK

Kumanda vidası sayesinde yarma ucunun otomatik olarak geri çekilmesi.



Yedek parça

Ürün No.	Ürün adı
54-2-M	Somun kesici için yeni ayırıcı keskiler

Parçasıdır

Ürün No.	Ürün adı
WT-005	Çektirme ürün yelpazesi - otomotiv
K-54-B	Mekanik somun kırıcı seti
EVLW-2-KFZ	Otomotiv için satış amaçlı pano
EVLW-2-NFZ	Otomotiv / ticari araçlar / tarım makineleri için satış amaçlı pano

In yedek parçası

Ürün No.	Ürün adı
WT-005	Çektirme ürün yelpazesi - otomotiv



De içinde bulunur

Ürün No.

Ürün adı

WT-005

Çektirme ürün yelpazesi - otomotiv

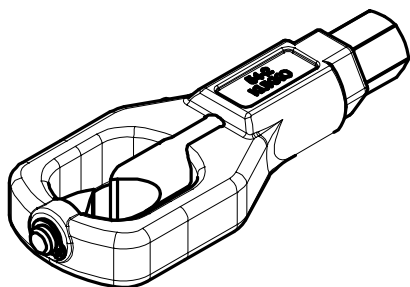
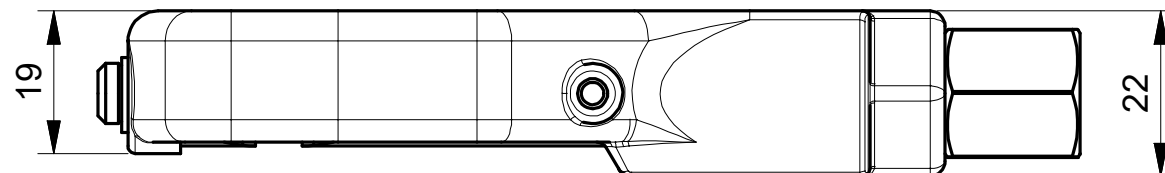
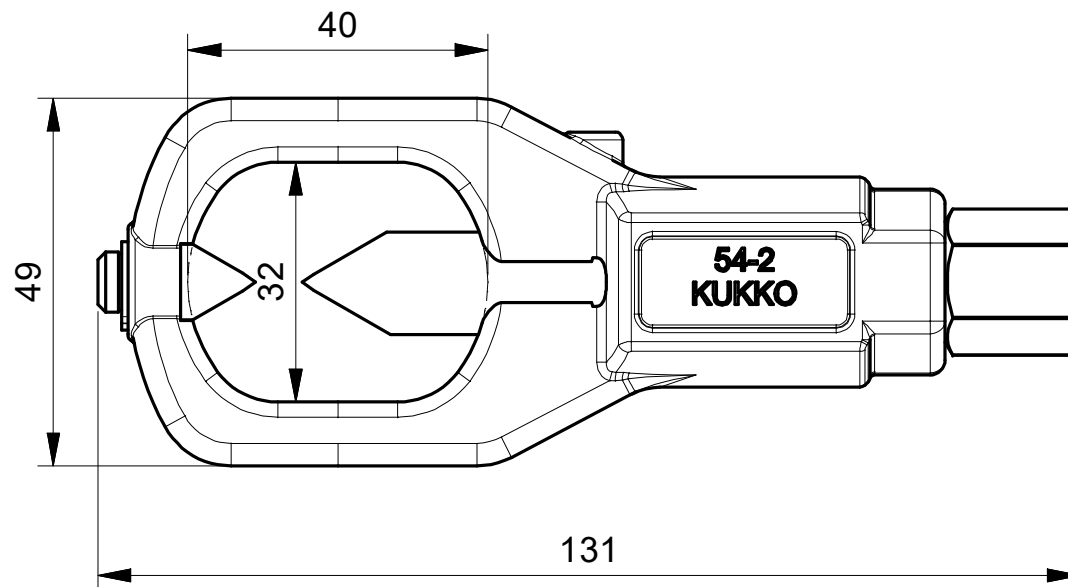
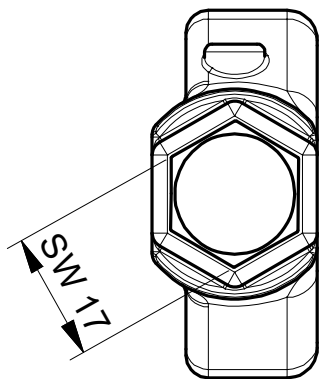

 Kleinbongartz & Kaiser oHG Werkzeugfabrik Hilden - Germany	Dokumentname:		Toleranz: DIN ISO 2768-m	
	Dokumentbeschreibung:		Material:	
	Erstellt von: Schultes	Erstellungsdatum: 04/10/2019	Maßstab: 1:1	
Teilbeschreibung: Zweischneidiger mechanischer Mutternsprenger			Wärmebehandlung / Härte:	
			Oberflächenbehandlung:	
Artikelnummer / ZNR.: 54-2	Dokumentversion: -		Schutzvermerk ISO 16016 beachten	