



Nome del prodotto

Spaccadadi meccanici a due taglienti







Spaccadadi a due taglienti con doppio effetto per dadi della classe 5, 6 e 8 bloccati in modo irreparabile.

Num. art. 54-3

Serie 54

EAN 4021176170799



	Attributo tecnico	Metrico	Imperiale
	Grandezza = per dadi	17 - 36 mm	3/4 - 1 3/8 inch
	Larghezza di taglio punta (mm)	16 mm	
	Lunghezza senza asta filettata (mm)	134 mm	
	Esagono esterno	19 mm	
	Peso	0.72 kg	
	Larghezza di taglio punta (pollici)		5/8 inch
	Lunghezza senza asta filettata (pollici)		5 1/4 inch



Tecnologie



PULLBACK

Arretramento automatico dello scalpello a scatto elastico grazie alla vite di azionamento.



Pezzo di ricambio

Num. art.	Nome del prodotto
54-3-M	Nuova punta per spaccadadi

é parte di

Num. art.	Nome del prodotto
K-54-B	Set meccanico di spaccadadi
EVLW-2-KFZ	Display di vendita Automotive
EVLW-2-NFZ	Display di vendita del settore automotive/veicoli commerciali/macchine agricole

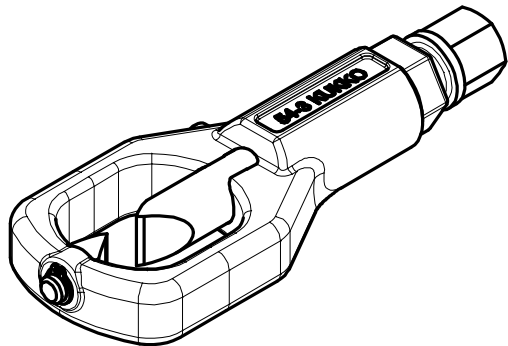
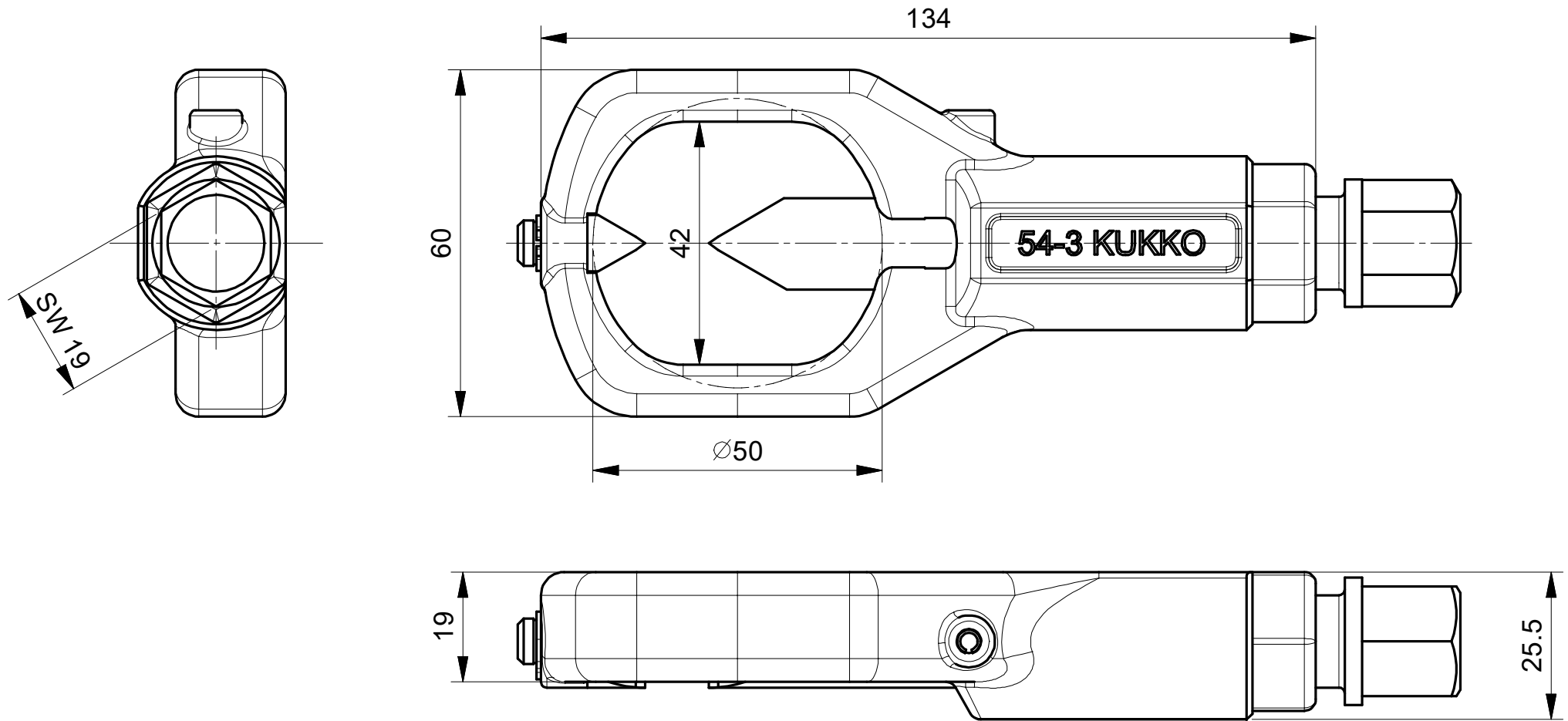

 Kleinbongartz & Kaiser oHG Werkzeugfabrik Hilden - Germany	Dokumentname: 54-3_Muttersprenger		Toleranz: DIN ISO 2768-m	
	Dokumentbeschreibung: Baugruppe		Material: Hoch legierter Werkzeugstahl / High alloy tool steel	
	Erstellt von: Breidenbach	Erstellungsdatum: 29/05/2019	Maßstab: 1:1	
Teilbeschreibung: Zweischneidiger mechanischer Mutternsprenger/ Double-edged mechanic nut splitter			Wärmebehandlung / Härte: vergüteter Stahl/ tempered steel	
			Oberflächenbehandlung: -	
Artikelnummer / ZNR.: 54-3	Dokumentversion: -	Schutzvermerk ISO 16016 beachten		