



Ürün adı *

Uzun hidrolik mil

Özellikle sıkı yatakları, dişlileri, rondelaları vb. çıkarmak için.

Ürün No. 8-2-K

Seriler 8

EAN 4021176034831



Teknik özellik

Metrik

İmparatorluk

	Hidrolik mil diş uzunluğu	250 mm	9 7/8 inch
	Diş	G 1 1/8"	G 1 1/8"
	Strok	10 mm	3/8 inch
max.	İzin verilen maksimum yük	20 t	22 US t
	Maks. tork	30 Nm	22 ft lb
	Ağırlık	9.795 kg	



Teknolojiler



HYDRAULIC

Hidrolik işlevli çekme aletleri.



Yedek parça

Ürün No.	Ürün adı
8-2	Miller için hidrolik
8-K	8-2 için mil seti 250mm
8-2-ERS	Aşınan parça seti

In yedek parçası

Ürün No.	Ürün adı
11-1-B	Uzun hidrolik milli 3 kollu çektirme, ekstra ağır iş tipi
11-2-B	Uzun hidrolik milli 3 kollu çektirme, ekstra ağır iş tipi
11-3-B	Uzun hidrolik milli 3 kollu çektirme, ekstra ağır iş tipi
11-1-BV	3 kollu üniversal çektirme (derinliği ayarlanabilir) ve uzun hidrolik mil
11-2-BV	3 kollu üniversal çektirme (derinliği ayarlanabilir) ve uzun hidrolik mil

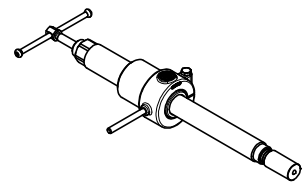
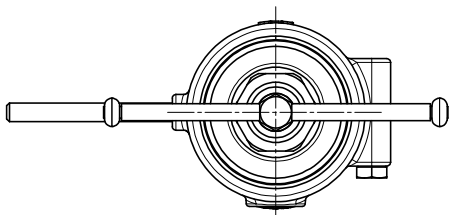
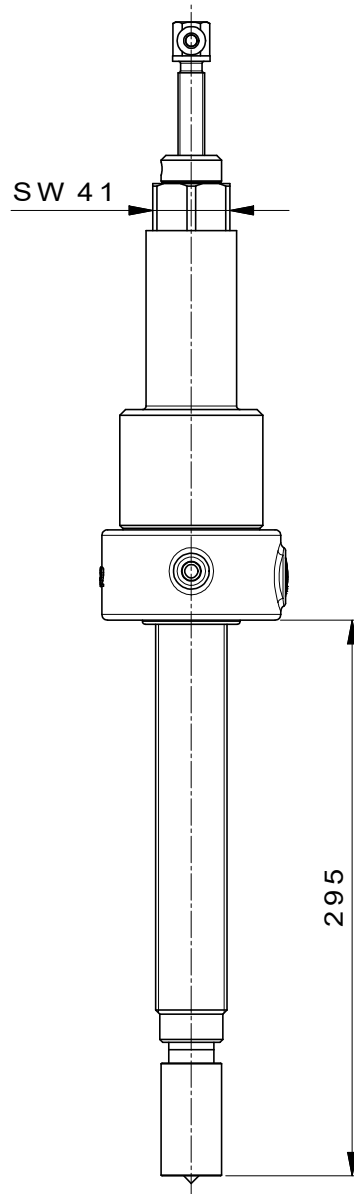
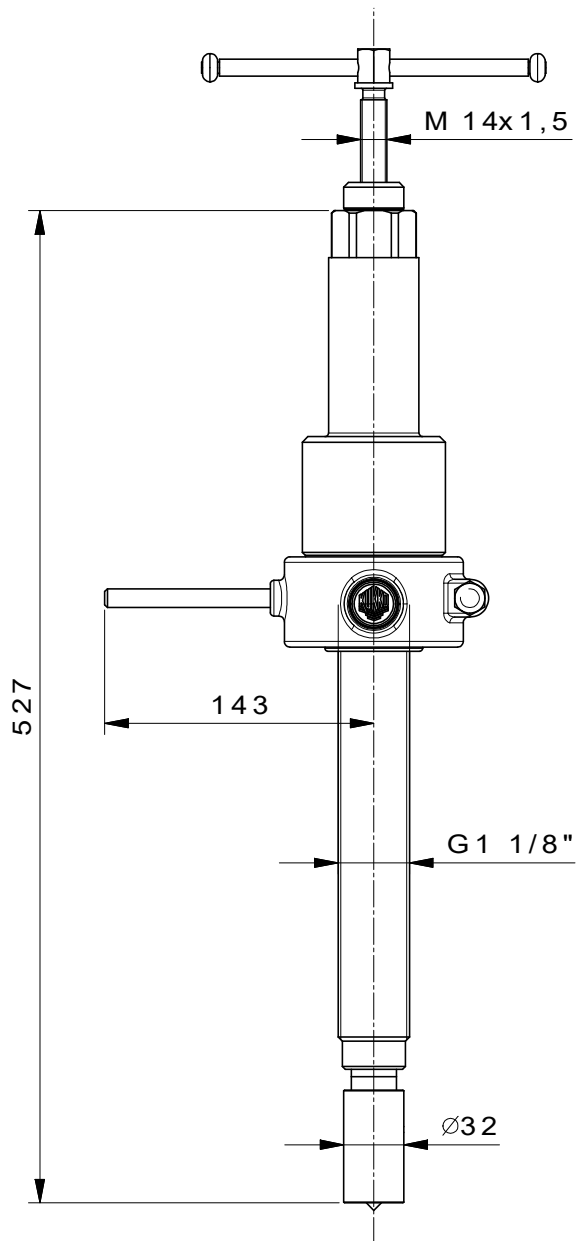

 Kleinbongartz & Kaiser oHG Werkzeugfabrik Hilden - Germany	Dokumentname: 8-2-K_Lange Hydraulikspindel	Toleranz: DIN ISO 2768-m
	Dokumentbeschreibung: Baugruppe	Material: Vergütungsstahl/ heat treatable steel
Erstellt von: Breidenbach	Erstellungsdatum: 18/01/2019	Maßstab: 1:2
Teilbeschreibung: Lange Hydraulikspindel/ Long hydraulic spindle		Wärmebehandlung / Härte: -
		Oberflächenbehandlung: -
Artikelnummer / ZNR: 8-2-K	Dokumentversion: -	Schutzvermerk ISO 16016 beachten