



产品名称 \*

## 长液压主轴





用于拉拔特别大的轴承、齿轮、圆盘等。

编号 8-2-K

系列 8

EAN 4021176034831



| 技术规格  | 公制       | 英制         |
|---|----------|------------|
|  液压主轴螺纹长度  | 250 mm   | 9 7/8 inch |
|  螺杆        | G 1 1/8" | G 1 1/8"   |
|  行程        | 10 mm    | 3/8 inch   |
| max. 最大负载   | 20 t     | 22 US t    |
|  max. 最大扭矩 | 30 Nm    | 22 ft lb   |
|  重量        | 9.795 kg |            |



## 技术



液压

具有液压功能的拉马。





## 配件

| 编号      | 产品名称              |
|---------|-------------------|
| 8-2     | 液压主轴              |
| 8-K     | 250 mm 主轴插件用于 8-2 |
| 8-2-ERS | 易损件套装             |

## 配件

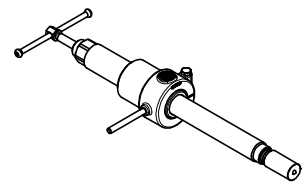
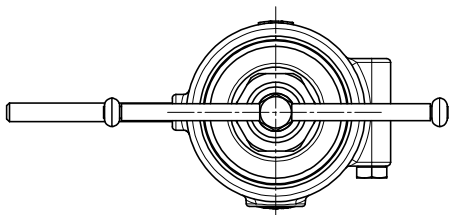
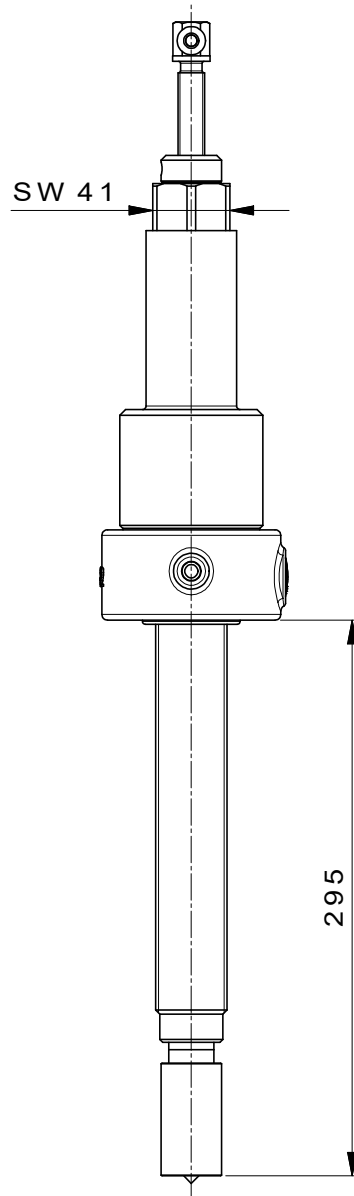
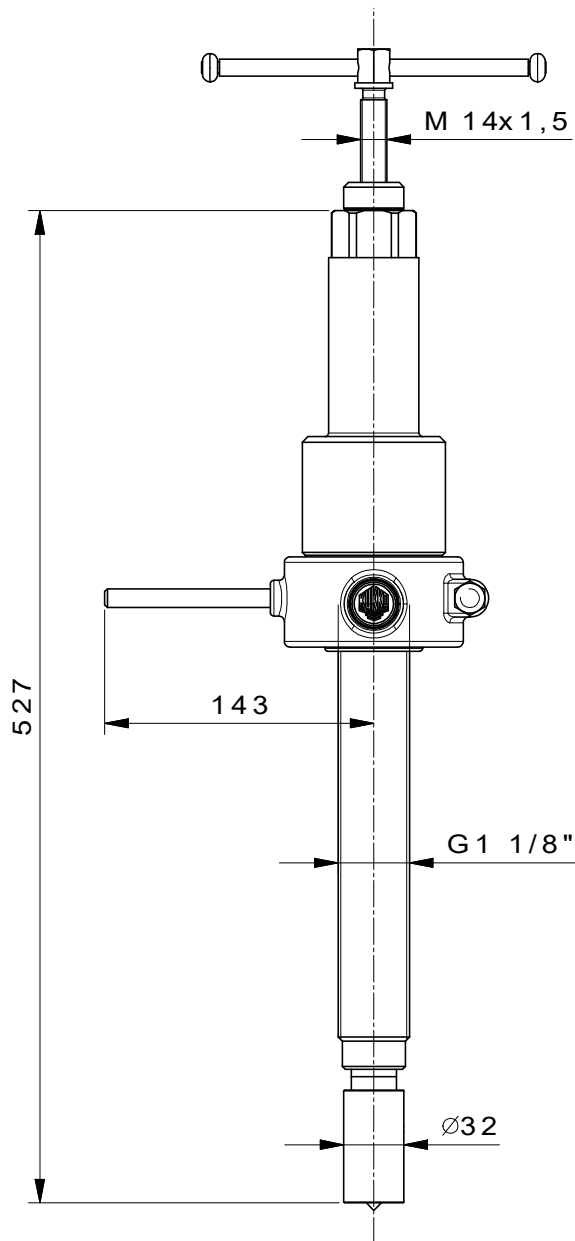
| 编号      | 产品名称             |
|---------|------------------|
| 11-1-B  | 三爪拉马带长液压主轴，确保高性能 |
| 11-2-B  | 三爪拉马带长液压主轴，确保高性能 |
| 11-3-B  | 三爪拉马带长液压主轴，确保高性能 |
| 11-1-BV | 三爪拉马带可调节范围和长液压主轴 |
| 11-2-BV | 三爪拉马带可调节范围和长液压主轴 |



|  |   |   |
|--|---|---|
|  <b>Kleinbongartz &amp; Kaiser oHG</b><br>Werkzeugfabrik Hilden - Germany | Dokumentname:<br>8-2-K_Lange Hydraulikspindel | Toleranz:<br>DIN ISO 2768-m                           |
|  | Dokumentbeschreibung:<br>Baugruppe            | Material:<br>Vergütungsstahl/<br>heat treatable steel |
| Erstellt von:<br>Breidenbach   | Erstellungsdatum:<br>18/01/2019               | Maßstab:<br>1:2                                       |
| Teilbeschreibung:<br>Lange Hydraulikspindel/ Long hydraulic spindle  |   | Wärmebehandlung / Härte:<br>-                         |
|  |   | Oberflächenbehandlung:<br>-                           |
| Artikelnummer / ZNR:<br>8-2-K  | Dokumentversion:<br>-                         | Schutzvermerk<br>ISO 16016<br>beachten                |