



Nome do produto

## Eixo hidráulico longo





Para remover rolamentos, engrenagens, discos, etc. particularmente fixos.

Artigo Nº 8-2-M

Série 8

EAN 4021176034916



|   | <b>Características</b>                      | <b>Métrico</b> | <b>Polegada</b> |
|---|---|----------------|-----------------|
|  | Comprimento das roscas para eixo hidráulico | 350 mm         | 13 3/4 inch     |
|  | Roscas                                      | G 1 1/8"       | G 1 1/8"        |
|  | Elevação                                    | 10 mm          | 3/8 inch        |
| max.  | Carga máxima permitida                      | 20 t           | 22 US t         |
|   | Binário máx.                                | 30 Nm          | 22 ft lb        |
|  | Peso  | 11.14 kg       |                 |



## Tecnologias



### **HIDRÁULICO**

Ferramentas de extração com função hidráulica.



## Peça de substituição

| <b>Artigo Nº</b> | <b>Nome do produto</b>             |
|------------------|------------------------------------|
| 8-2              | Sistema hidráulico para eixos      |
| 8-M              | Inserção de eixo de 350mm para 8-2 |
| 8-2-ERS          | Conjunto de peça de desgaste       |

## é uma peça de substituição de

| <b>Artigo Nº</b> | <b>Nome do produto</b>   |
|------------------|--|
| 18-5-B           | Dispositivo de extração hidráulico (incluindo eixo mecânico)   |
| 20-5-H           | Extrator universal de 2 braços com profundidade de fixação ajustável e eixo hidráulico longo (incluindo eixo mecânico) |

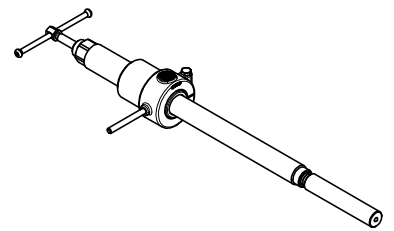
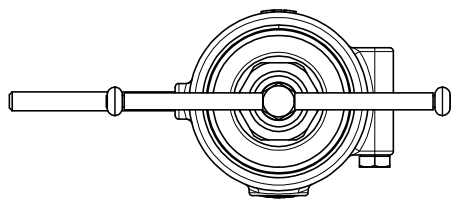
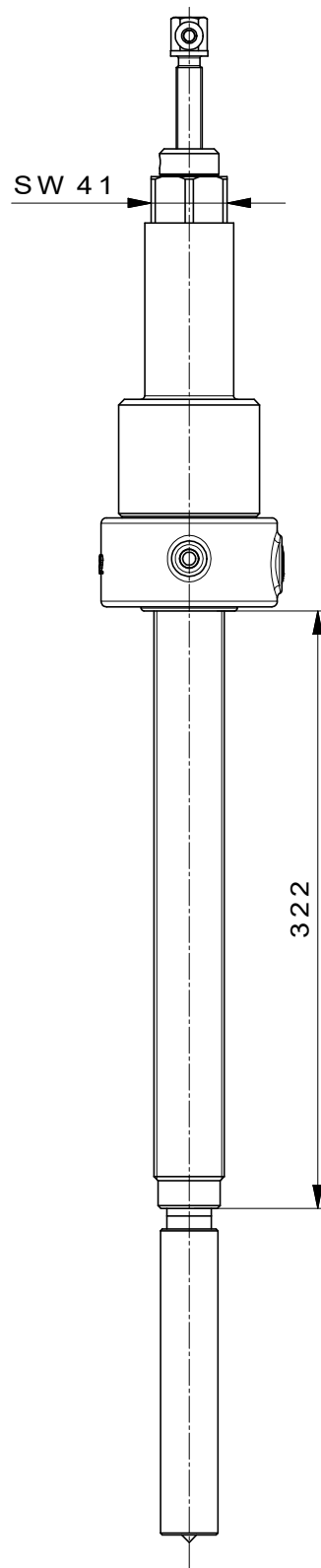
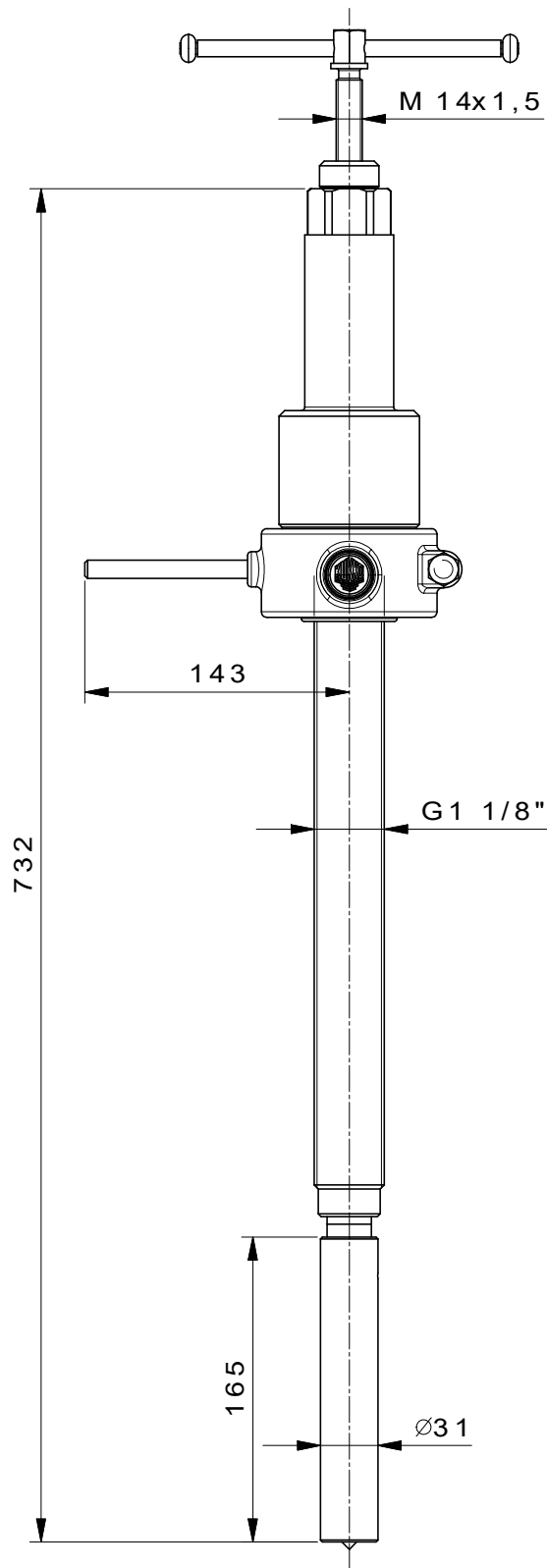

|   |  |  |   |                                     |
|---|--|--|---|-------------------------------------|
|  | <b>Kleinbongartz &amp; Kaiser oHG</b><br>Werkzeugfabrik Hilden - Germany |  | Dokumentname:<br>8-2-M_Lange Hydraulikspindel         | Toleranz:<br>DIN ISO 2768-m         |
|   | Dokumentbeschreibung:<br>BAUGRUPPENZEICHNUNG                             |  | Material:<br>Vergütungsstahl/<br>heat treatable steel | Maßstab:<br>1:2                     |
| Teilbeschreibung:<br>Lange Hydraulikspindel/ Long hydraulic spindle                 |  | Wärmebehandlung / Härte:<br>Oberflächenbehandlung: |   |                                     |
| Artikelnummer / ZNR:<br>8-2-M   | Dokumentversion:<br>-  | Erstellungsdatum:<br>19/04/2017                    |   | Schutzvermerk<br>ISO 16016 beachten |