



产品名称

长液压主轴





用于拉拔特别大的轴承、齿轮、圆盘等。

编号 8-2-M

系列 8

EAN 4021176034916



技术规格	公制	英制
 液压主轴螺纹长度	350 mm	13 3/4 inch
 螺杆	G 1 1/8"	G 1 1/8"
 行程	10 mm	3/8 inch
max. 最大负载	20 t	22 US t
 max. 最大扭矩	30 Nm	22 ft lb
 重量	11.14 kg	



技术



液压

具有液压功能的拉马。



配件

编号	产品名称
8-2	液压主轴
8-M	350 mm 主轴插件用于 8-2
8-2-ERS	易损件套装

配件

编号	产品名称
18-5-B	液压拉拔装置（包含机械压力螺钉）
20-5-H	通用两爪拉马带可调节范围和长液压主轴（包含机械压力螺钉）

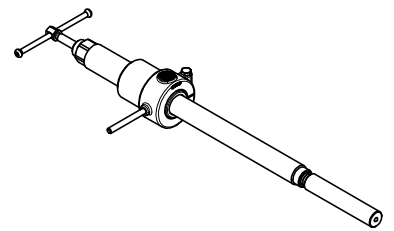
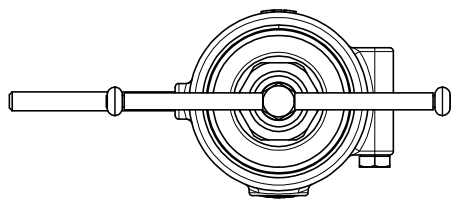
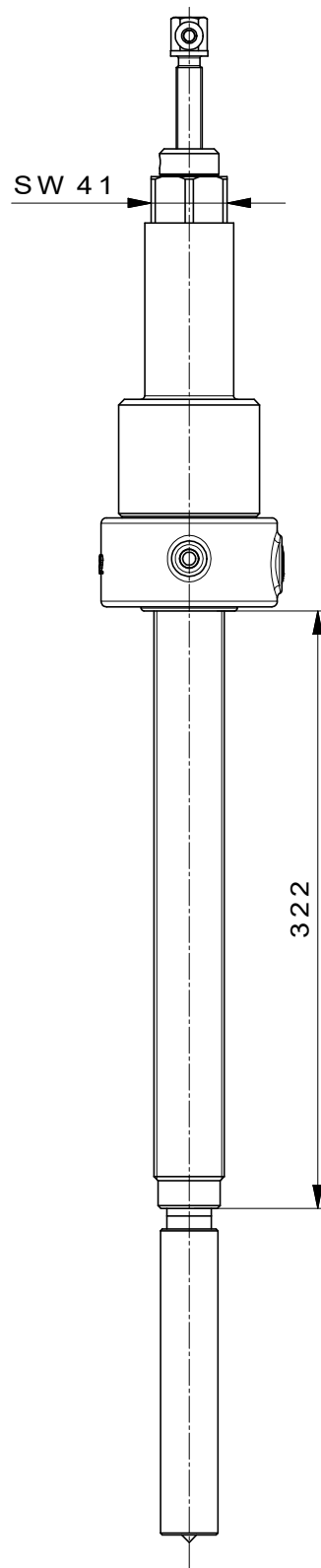
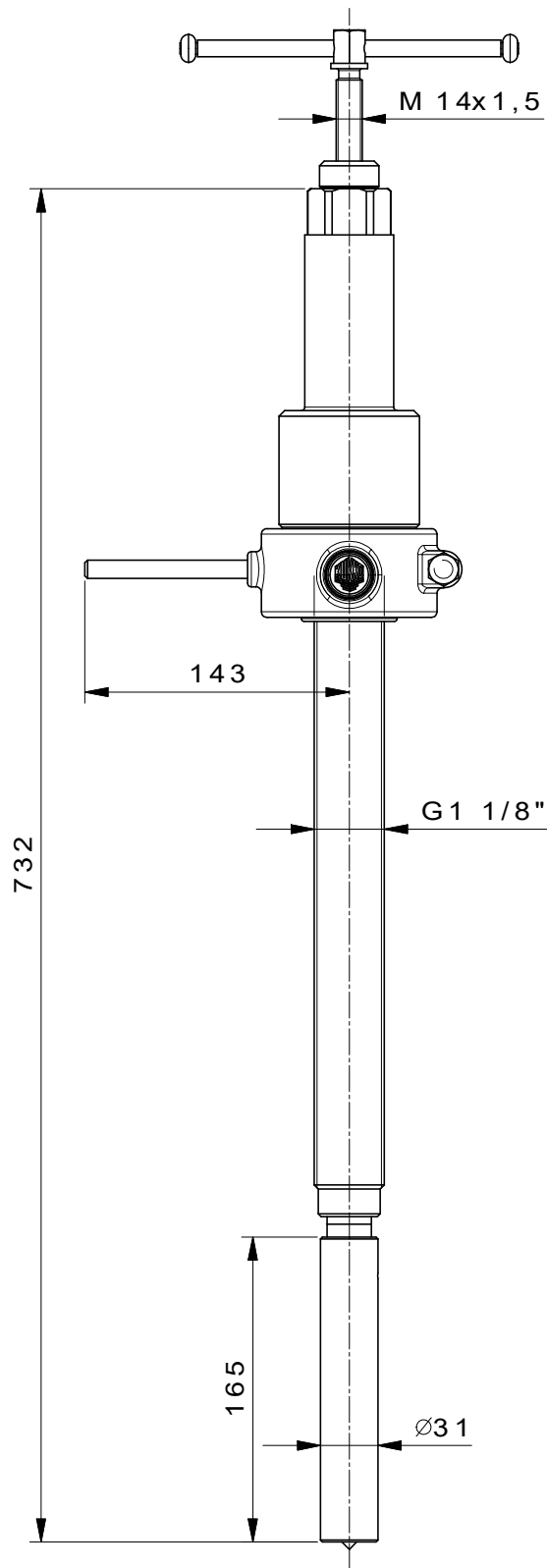

 Kleinbongartz & Kaiser oHG Werkzeugfabrik Hilden - Germany	Dokumentname: 8-2-M_Lange Hydraulikspindel	Toleranz: DIN ISO 2768-m
	Dokumentbeschreibung: BAUGRUPPENZEICHNUNG	Material: Vergütungsstahl/ heat treatable steel
Erstellt von: Breidenbach	Erstellungsdatum: 19/04/2017	Maßstab: 1:2
Teilbeschreibung: Lange Hydraulikspindel/ Long hydraulic spindle		Wärmebehandlung / Härte: Oberflächenbehandlung:
Artikelnummer / ZNR: 8-2-M	Dokumentversion: -	Schutzvermerk ISO 16016 beachten