



Product name

## Short hydraulic spindle.





For pulling particularly tight bearings, gears, discs, etc.

Art. No. 800

Series 800

EAN 4021176034343



	Technical attribute	Metric	Imperial
	Thread	W 1.1/2"-16(55°;16 Gang)	W 1.1/2"-16(55°;16 Gang)
	Stroke	10 mm	3/8 inch
	Wrench size	13 mm	
max.	Maximum load	10 t	11 US t
max.	Maximum torque	40 Nm	29.5 ft lb
	Weight	1.46 kg	



## Technologies



### HYDRAULIC

Pullers with hydraulic function.



## Spare part

<b>Art. No.</b>	<b>Product name</b>
800-ERS	Wearing parts set
800-REP	Factory overhaul
800017	Pressure pad
610075	Spindle
ERS-Oil	Hydraulic oil in spray bottle

## Part of

<b>Art. No.</b>	<b>Product name</b>
WT-010	Puller product range - commercial vehicles - TOP

## Spare part of

<b>Art. No.</b>	<b>Product name</b>
129-3-H	Ball joints extractor with short hydraulic spindle
229-2	Hydraulic wheel puller
818-0	Pulling device with hydraulic screw
818-100	Hydraulic bearing puller set
818-150	Hydraulic bearing puller set
818-215	Hydraulic bearing puller and extractor set
820-0	2-jaw puller with short hydraulic spindle



## Spare part of

<b>Art. No.</b>	<b>Product name</b>
845-150	Hydraulic "4 Pullers" - Set with self-centering pulling jaws
845-250	Hydraulic "6 Pullers" - Set with self-centering pulling jaws
845-851	Hydraulic "10 Pullers" - Set with self-centering pulling jaws
845-855	Universal hydraulic puller set with separator
845-858	Universal hydraulic puller and extractor set with self-centering jaws with separator
124-20-B	2-jaw puller for vibration dampers with short hydraulic spindle and quick adjusting jaws
844-1-B	Universal 2-jaw puller with short hydraulic spindle and self-centering jaws
844-2-B	Universal 2-jaw puller with short hydraulic spindle and self-centering jaws
844-3-B	Universal 2-jaw puller with short hydraulic spindle and self-centering jaws
844-4-B	Universal 2-jaw puller with short hydraulic spindle and self-centering jaws
844-5-B	Universal 2-jaw puller with short hydraulic spindle and self-centering jaws
845-1-B	Universal 3-jaw puller with short hydraulic spindle and self-centering jaws
845-2-B	Universal 3-jaw puller with short hydraulic spindle and self-centering jaws
845-3-B	Universal 3-jaw puller with short hydraulic spindle and self-centering jaws
845-4-B	Universal 3-jaw puller with short hydraulic spindle and self-centering jaws



## Spare part of

<b>Art. No.</b>	<b>Product name</b>
845-5-B	Universal 3-jaw puller with short hydraulic spindle and self-centering jaws
20-3-H	2-jaw puller with short hydraulic spindle
20-30-H	2-jaw puller with short hydraulic spindle
880-800	Universal press frame for silent bushings

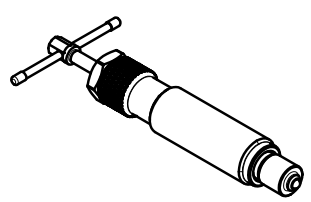
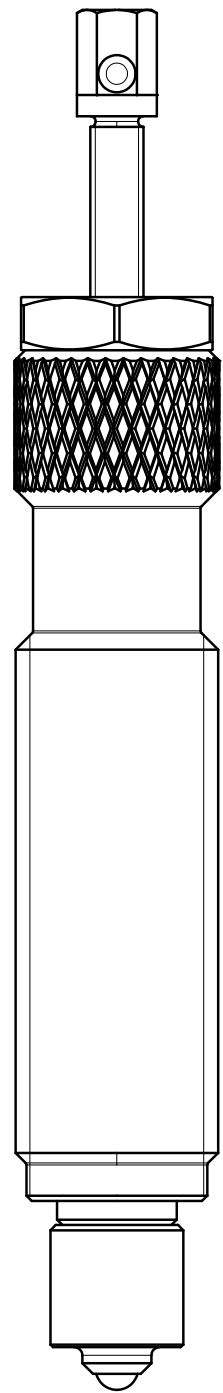
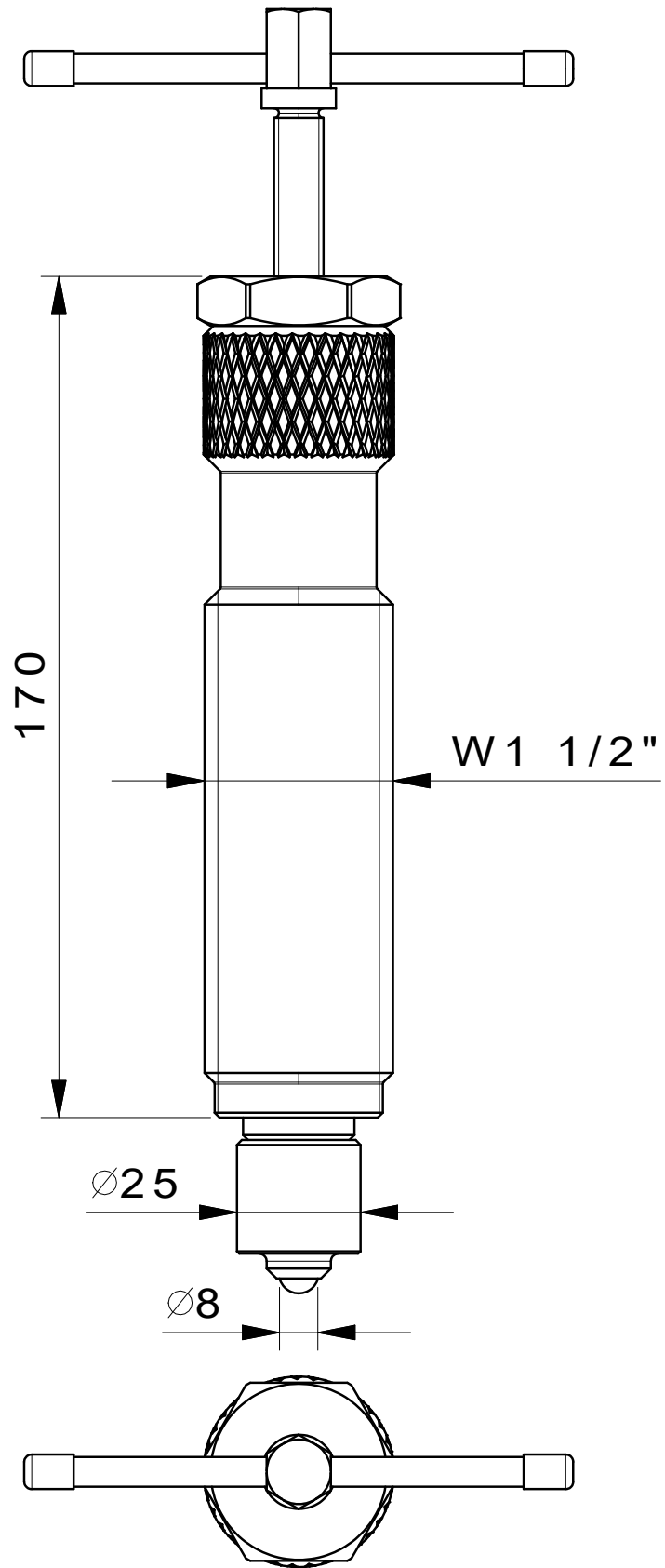

 <b>Kleinbongartz &amp; Kaiser oHG</b> Werkzeugfabrik Hilden - Germany	Dokumentname: 800_Kurze Hydraulikspindel		Toleranz: DIN ISO 2768-m
	Dokumentbeschreibung: Baugruppe		Material: Vergütungsstahl/ heat treatable steel
Erstellt von: Breidenbach	Erstellungsdatum: 25/08/2017		Maßstab: 1:1
Teilbeschreibung: Kurze Hydraulikspindel/ Short hydraulic spindle			Wärmebehandlung / Härte: vergüteter Stahl/ tempered steel
			Oberflächenbehandlung:
Artikelnummer / ZNR.: 800	Dokumentversion: -	Schutzvermerk ISO 16016 beachten	