



Produktnavn

Kort hydraulisk spindel





Til aftrækning af særligt fastsiddende lejer, tandhjul, skiver etc.

Varenr. 801

Serie 800

EAN 4021176784446



	Teknisk egenskab	Metrisk	Tomme
	Gevind	W 1.1/2"-16(55°;16 Gang)	W 1.1/2"-16(55°;16 Gang)
	Slaglængde	10 mm	3/8 inch
	Nøglevidde	19 mm	
max.	Maksimal tilladt belastning	15 t	16.5 US t
 max.	Maks. drejningsmoment	70 Nm	51.5 ft lb
	Vægt	1.47 kg	



Teknologier



HYDRAULIC

Aftrækningsværktøj med hydraulikfunktion.



Reservedel

Varenr.	Produktnavn
801-REP	Istandsættelse på fabrikken
801-ERS	Sliddelssæt
800017	Trykstykke
612075	Spindel
ERS-Oil	Hydraulikolie i doseringsflaske

Er reservedel til

Varenr.	Produktnavn
128-G-6-H15	Hydraulisk styrearmsaftrækker i klokkeform
129-3-H	Kugleledsudsøder med kort hydraulisk spindel
129-4-H	Kugleledsudsøder med kort hydraulisk spindel
129-5-H	Kugleledsudsøder med kort hydraulisk spindel
229-3	Hydraulisk hjulnavaftrækker
880-801	Universalpresseramme til silentbøsninger
129-3	Kugleledsudsøder med udveksling til mellemstore lastbiler, busser og byggekøretøjer
129-4	Kugleledsudsøder med udveksling til tunge lastbiler, busser og byggekøretøjer.

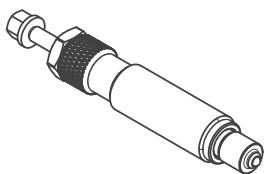
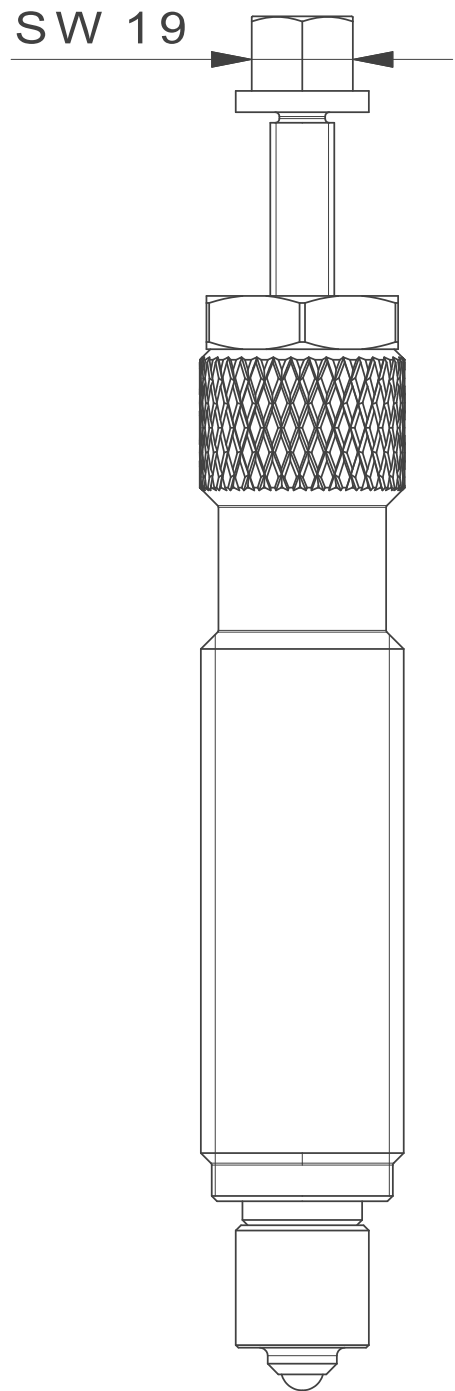
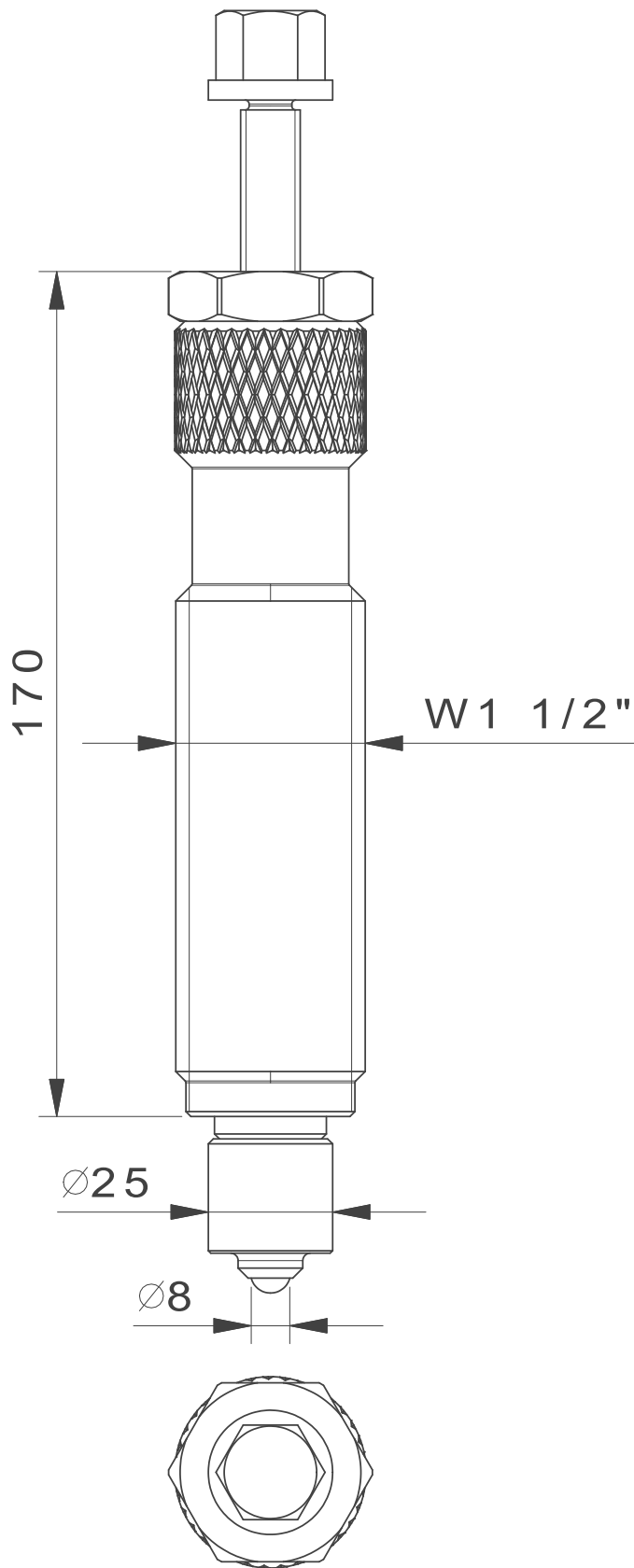

 <p>Kleinbongartz & Kaiser oHG Werkzeugfabrik Hilden - Germany</p>	Dokumentname: 801_Kurze Hydraulikspindel		Toleranz: DIN ISO 2768-m
	Dokumentbeschreibung: Baugruppe		Material: Vergütungsstahl/ heat treatable steel
	Erstellt von: Breidenbach	Erstellungsdatum: 25/08/2017	Maßstab: 1:1
Teilbeschreibung: Kurze Hydraulikspindel/ Short hydraulic spindle		Wärmebehandlung / Härte: vergüteter Stahl/ tempered steel	
		Oberflächenbehandlung:	
Artikelnummer / ZNR.: 801	Dokumentversion: -	Schutzvermerk ISO 16016 beachten	