



Productnaam

## Korte hydraulische spindels.





voor het lostrekken van bijzonder vastzittende lagers,  
tandwielen enz

Art nr. 801

Serie 800

EAN 4021176784446



|                                                                                            | Technisch kenmerk             | Metrisch                    | Imperial                    |
|--------------------------------------------------------------------------------------------|-------------------------------|-----------------------------|-----------------------------|
|         | Schroefdraad                  | W 1.1/2"-16(55°;16<br>Gang) | W 1.1/2"-16(55°;16<br>Gang) |
|         | Slag                          | 10 mm                       | 3/8 inch                    |
|         | Sleutelwijdte                 | 19 mm                       |                             |
| max.                                                                                       | Maximaal toegestane belasting | 15 t                        | 16.5 US t                   |
| <br>max. | Max. aandraaimoment           | 70 Nm                       | 51.5 ft lb                  |
|         | Gewicht                       | 1.47 kg                     |                             |



## Technologieën



### **HYDRAULIC**

Trekgereedschap met hydraulische functie.



## Onderdeel

| <b>Art nr.</b> | <b>Productnaam</b>            |
|----------------|-------------------------------|
| 801-REP        | Reparatieset voor 800         |
| 801-ERS        | reparatie onderdelen          |
| 800017         | Drukstuk                      |
| 612075         | Spindel                       |
| ERS-Oil        | hydrauliek olie in spayflacon |

## Is onderdeel van

| <b>Art nr.</b> | <b>Productnaam</b>                                                                                          |
|----------------|-------------------------------------------------------------------------------------------------------------|
| 128-G-6-H15    | Hydraulische stuurkogeltrekker in klokvorm                                                                  |
| 129-3-H        | Kogelgewricht-uitdrukker met korte hydraulische spindel                                                     |
| 129-4-H        | Kogelgewricht-uitdrukker met korte hydraulische spindel                                                     |
| 129-5-H        | Kogelgewricht-uitdrukker met korte hydraulische spindel                                                     |
| 229-3          | Hydraulische wielnaaftrekkers                                                                               |
| 880-801        | Universpersraam voor silentbussen                                                                           |
| 129-3          | Trekkers voor kogelgewrichten met heveloverbrenging voor middelzware vrachtwagens, bussen en bouwvoertuigen |
| 129-4          | Trekkers voor kogelgewrichten met heveloverbrenging voor zware vrachtwagens, bussen en bouwvoertuigen.      |

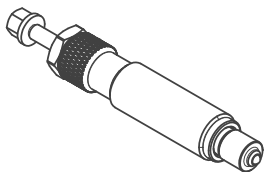
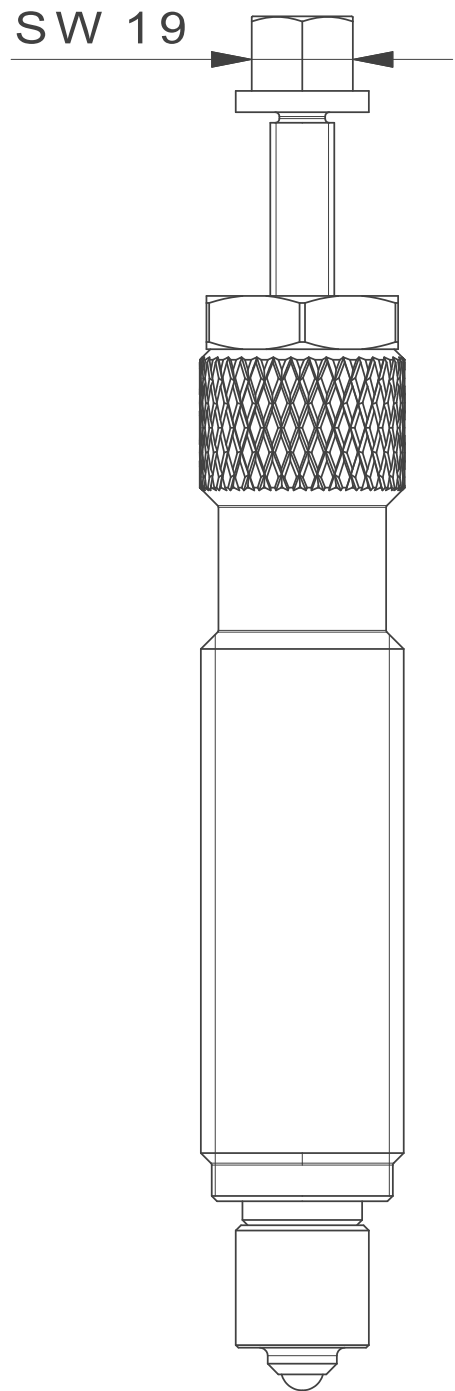
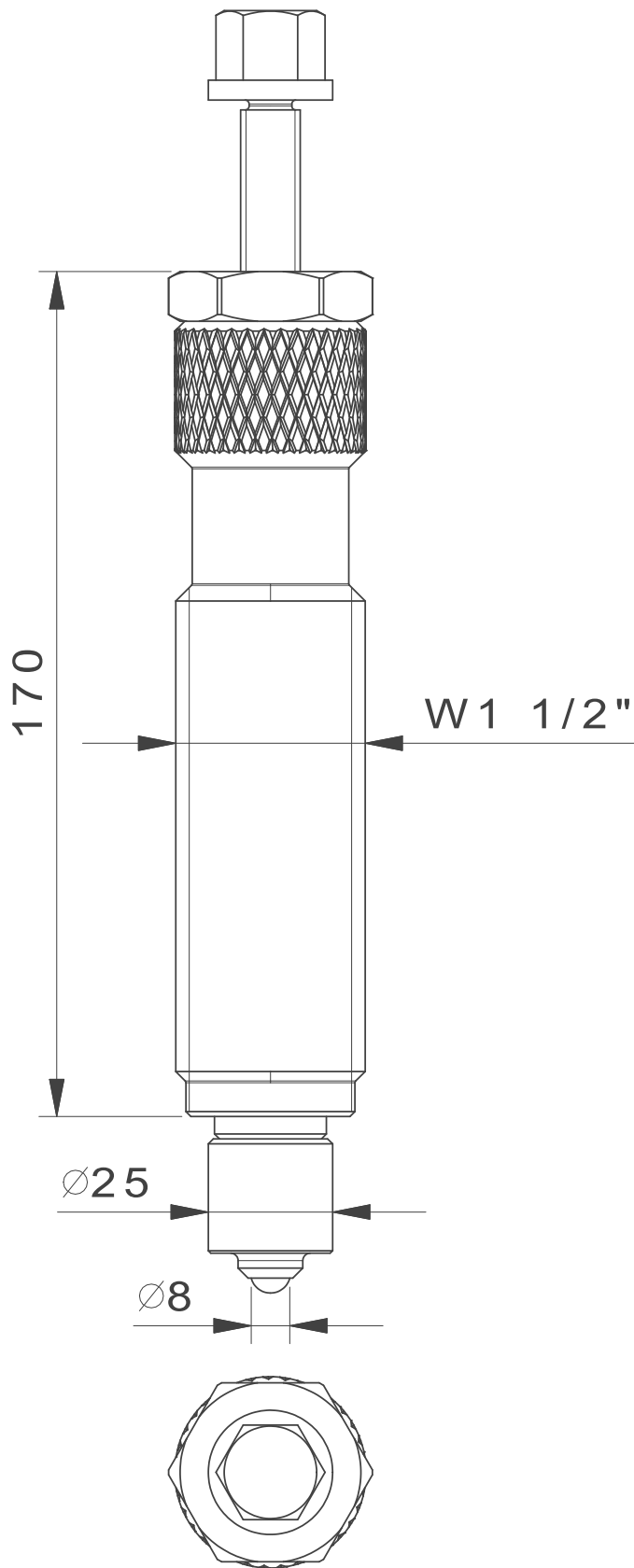

|                                                                                                                                                                                  |                                             |                                                              |                                                       |
|----------------------------------------------------------------------------------------------------------------------------------------------------------------------------------|---------------------------------------------|--------------------------------------------------------------|-------------------------------------------------------|
|  <p><b>Kleinbongartz<br/>&amp; Kaiser<br/>oHG</b><br/>Werkzeugfabrik<br/>Hilden - Germany</p> | Dokumentname:<br>801_Kurze Hydraulikspindel |                                                              | Toleranz:<br>DIN ISO 2768-m                           |
|                                                                                                                                                                                  | Dokumentbeschreibung:<br>Baugruppe          |                                                              | Material:<br>Vergütungsstahl/<br>heat treatable steel |
|                                                                                                                                                                                  | Erstellt von:<br>Breidenbach                | Erstellungsdatum:<br>25/08/2017                              | Maßstab:<br>1:1                                       |
| Teilbeschreibung:<br>Kurze Hydraulikspindel/ Short hydraulic spindle                                                                                                             |                                             | Wärmebehandlung / Härte:<br>vergüteter Stahl/ tempered steel |                                                       |
|                                                                                                                                                                                  |                                             | Oberflächenbehandlung:                                       |                                                       |
| Artikelnummer / ZNR.:<br>801                                                                                                                                                     | Dokumentversion:<br>-                       | Schutzvermerk<br>ISO 16016<br>beachten                       |                                                       |