



Produktnavn

## korte hydrauliske spindler





Til aftrækning af særligt fastsiddende lejer, tandhjul, skiver etc.

Varenr. 802

Serie 800

EAN 4021176784514



	<b>Teknisk egenskab</b>	<b>Metrisk</b>	<b>Tomme</b>
	Gevind	M40x1,5	M40x1,5
	Slaglængde	10 mm	3/8 inch
	Nøglevidde	19 mm	
max.	Maksimal tilladt belastning	20 t	22 US t
 max.	Maks. drejningsmoment	100 Nm	73.5 ft lb
	Vægt	1.55 kg	



## Teknologier



### HYDRAULIC

Aftrækningsværktøj med  
hydraulikfunktion.



## Reservedel

Varenr.	Produkt navn
802-REP	Istandsættelse på fabrikken
802-ERS	Sliddelssæt
800017	Trykstykke
612075	Spindel

## Er reservedel til

Varenr.	Produkt navn
880-802	Universalpresseramme til silentbøsninger

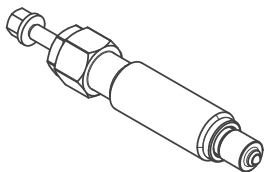
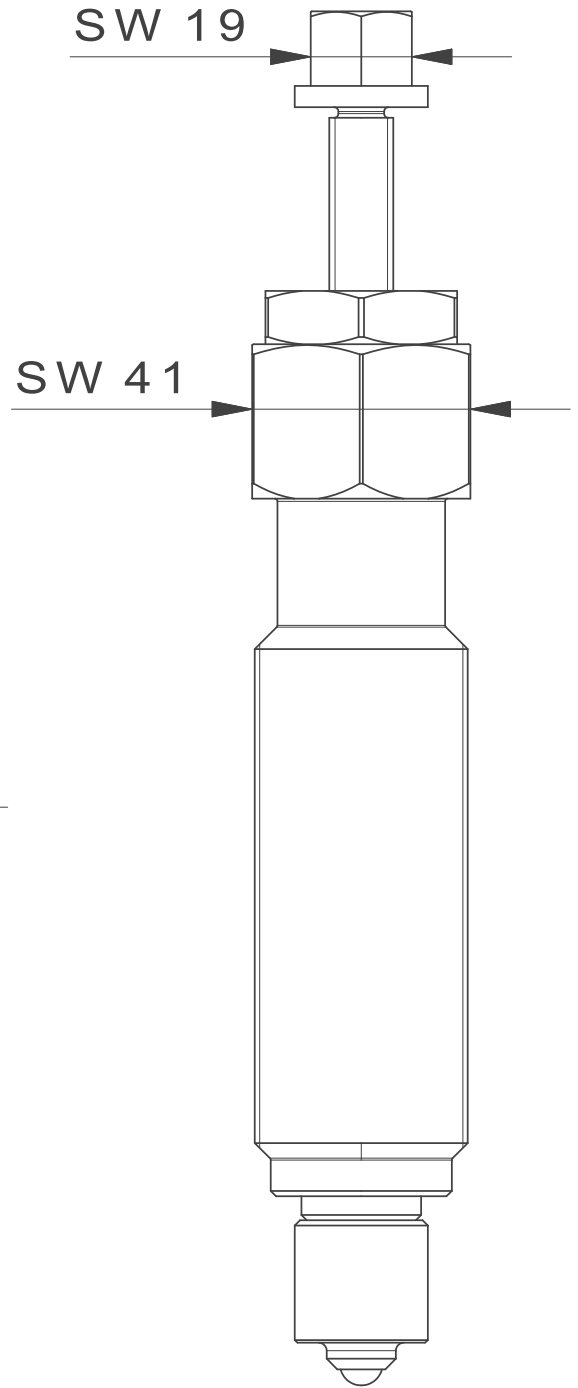
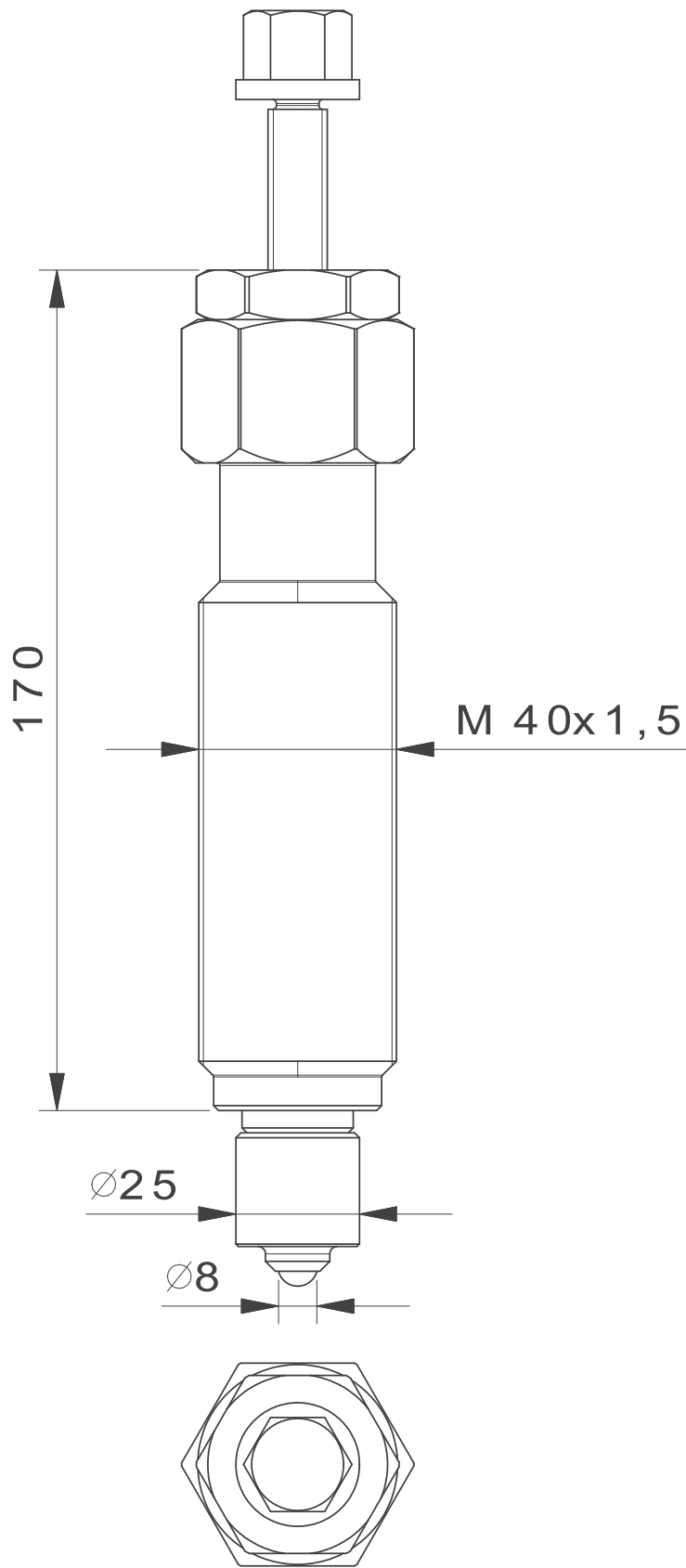

 <b>Kleinbongartz &amp; Kaiser oHG</b> Werkzeugfabrik Hilden - Germany	Dokumentname: 802_Kurze Hydraulikspindel		Toleranz: DIN ISO 2768-m	
	Dokumentbeschreibung: Baugruppe		Material: Vergütungsstahl/ heat treatable steel	
Erstellt von: Breidenbach	Erstellungsdatum: 25/08/2017		Maßstab: 1:1	
Teilbeschreibung: Kurze Hydraulikspindel/ Short hydraulic spindle			Wärmebehandlung / Härte: vergüteter Stahl/ tempered steel	
			Oberflächenbehandlung:	
Artikelnummer / ZNR.: 802	Dokumentversion: -	Schutzvermerk ISO 16016 beachten		