



Product name

## Short hydraulic spindles





For pulling particularly tight bearings, gears, discs, etc.

Art. No. 802

Series 800

EAN 4021176784514



	Technical attribute	Metric	Imperial
	Thread	M40x1,5	M40x1,5
	Stroke	10 mm	3/8 inch
	Wrench size	19 mm	
max.	Maximum load	20 t	22 US t
 max.	Maximum torque	100 Nm	73.5 ft lb
	Weight	1.55 kg	



## Technologies



### HYDRAULIC

Pullers with hydraulic function.



## Spare part

<b>Art. No.</b>	<b>Product name</b>
802-REP	Factory overhaul
802-ERS	Wearing parts set
800017	Pressure pad
612075	Spindle

## Spare part of

<b>Art. No.</b>	<b>Product name</b>
880-802	Universal press frame for silent bushings

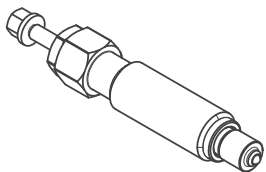
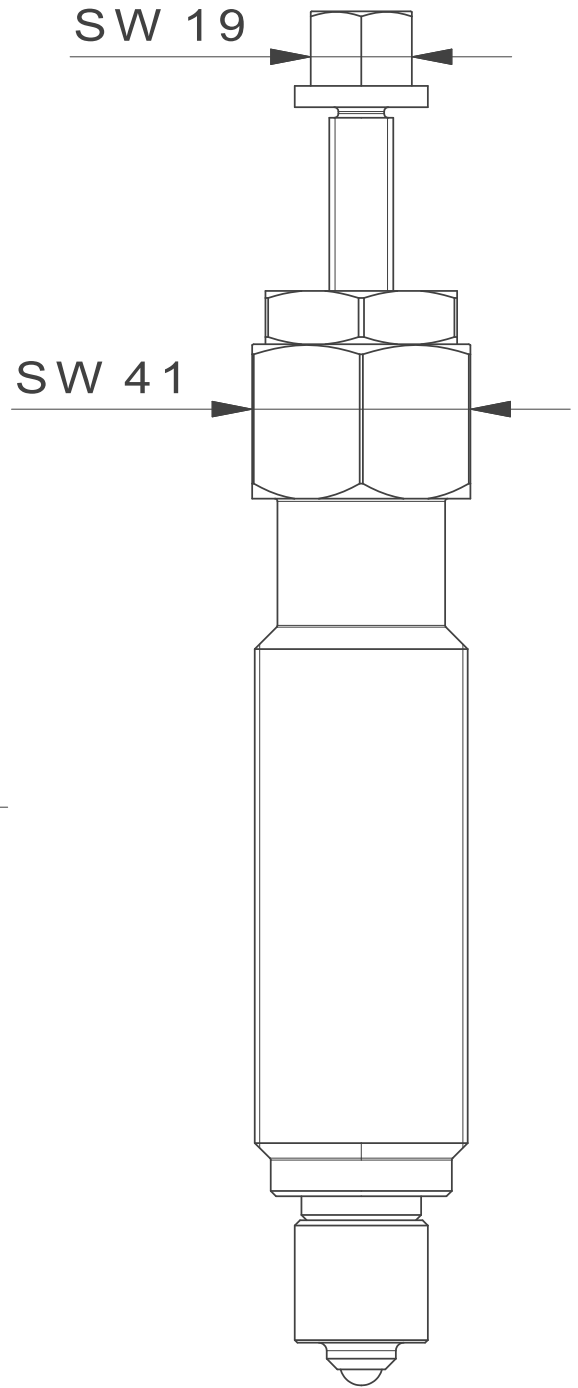
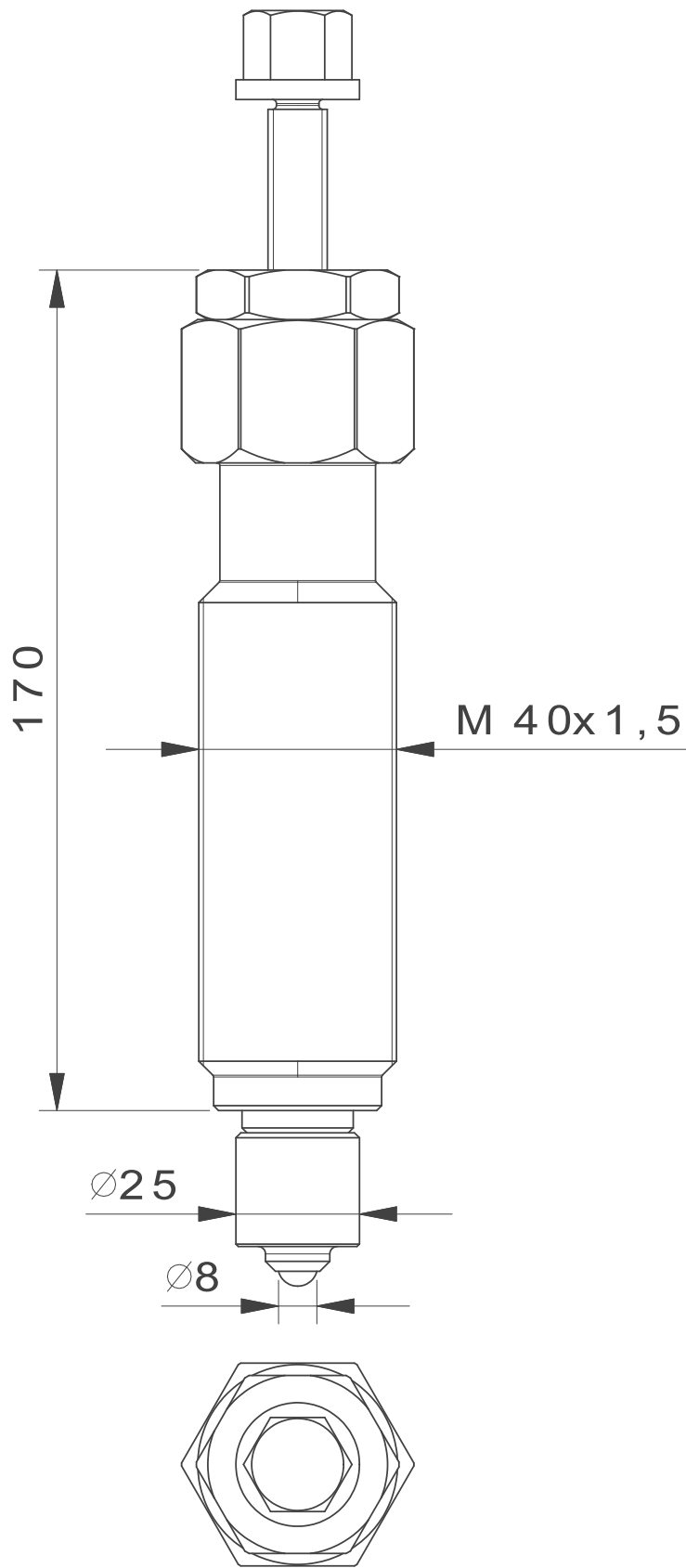

 <b>Kleinbongartz &amp; Kaiser oHG</b> Werkzeugfabrik Hilden - Germany	Dokumentname: 802_Kurze Hydraulikspindel		Toleranz: DIN ISO 2768-m	
	Dokumentbeschreibung: Baugruppe		Material: Vergütungsstahl/ heat treatable steel	
Erstellt von: Breidenbach	Erstellungsdatum: 25/08/2017		Maßstab: 1:1	
Teilbeschreibung: Kurze Hydraulikspindel/ Short hydraulic spindle			Wärmebehandlung / Härte: vergüteter Stahl/ tempered steel	
			Oberflächenbehandlung:	
Artikelnummer / ZNR.: 802		Dokumentversion: -	Schutzvermerk ISO 16016 beachten	