



Nombre del producto

Husillos hidráulicos cortos





Para extraer rodamientos, ruedas dentadas, discos, etc. especialmente fijados.

Núm. art. 802

Serie 800

EAN 4021176784514



| | Atributo técnico | Métrico | Imperial |
|--|------------------------|---------|------------|
|  | Rosca | M40x1,5 | M40x1,5 |
|  | Elevador | 10 mm | 3/8 inch |
|  | Envergadura de llave | 19 mm | |
| max. | Carga máxima admisible | 20 t | 22 US t |
|  max. | Momento de giro máximo | 100 Nm | 73.5 ft lb |
|  | Peso | 1.55 kg | |



Tecnologías



HYDRAULIC

Herramientas de tracción con función hidráulica.



Pieza de recambio

| Núm. art. | Nombre del producto |
|------------------|-----------------------------|
| 802-REP | Arreglo de taller |
| 802-ERS | Juego de piezas de desgaste |
| 800017 | Pieza de presión |
| 612075 | Husillo |

Es pieza de sustitucion de

| Núm. art. | Nombre del producto |
|------------------|--|
| 880-802 | Bastidor universal a presión para casquillos silenciosos |

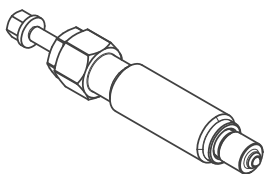
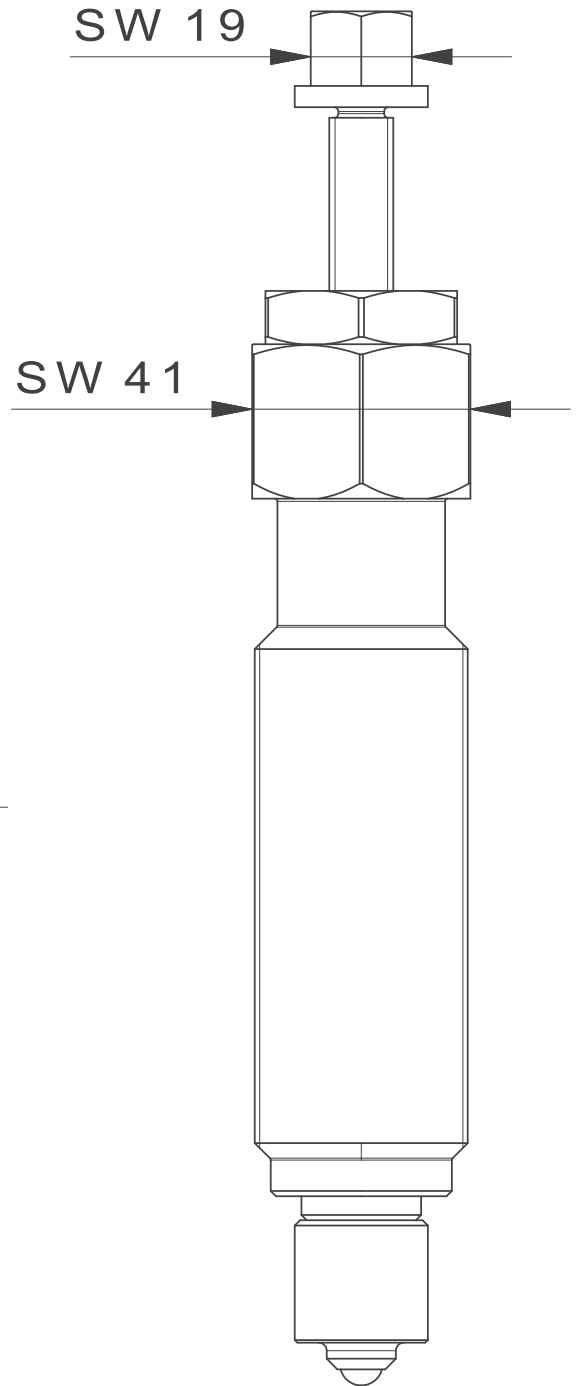
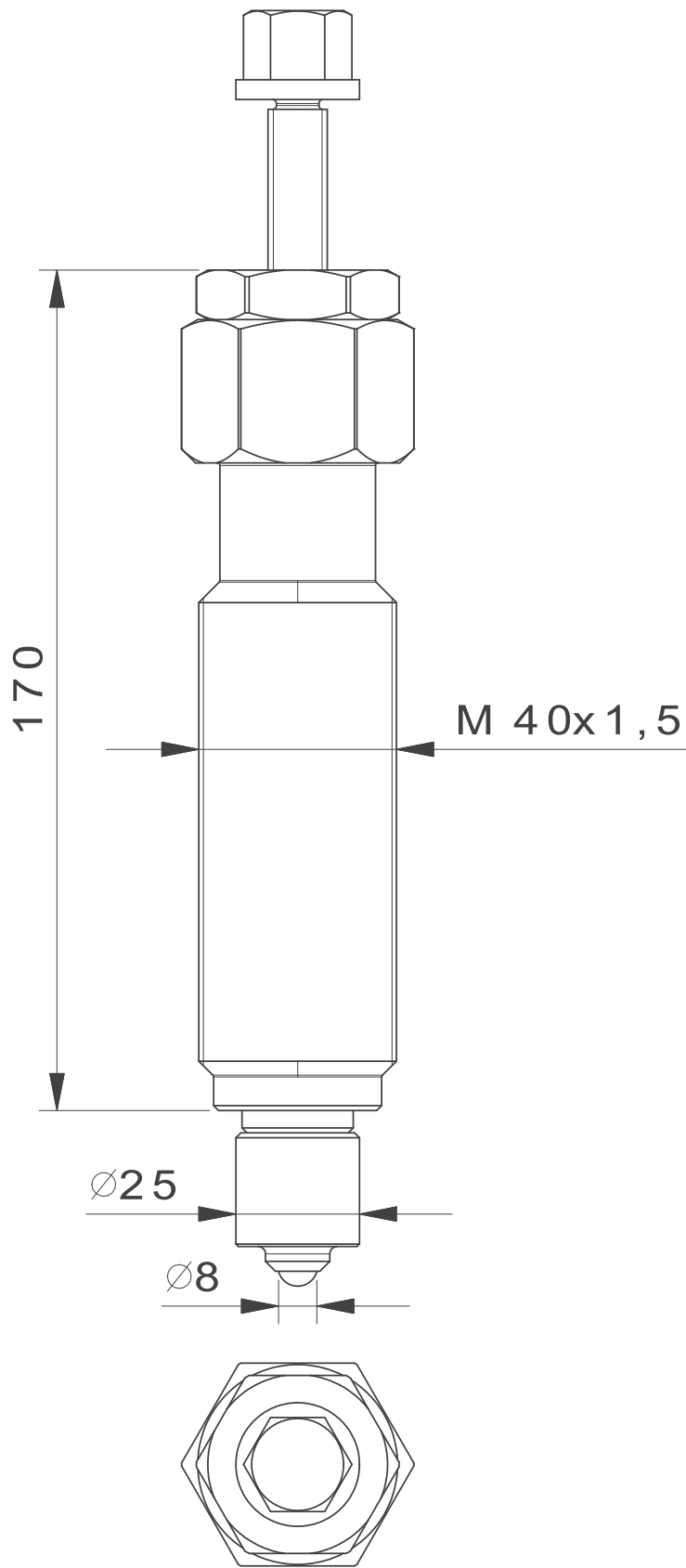

| | | | | |
|---|---|--|--|--|
|  Kleinbongartz & Kaiser oHG Werkzeugfabrik Hilden - Germany | Dokumentname: 802_Kurze Hydraulikspindel | | Toleranz: DIN ISO 2768-m | |
| | Dokumentbeschreibung: Baugruppe | | Material: Vergütungsstahl/ heat treatable steel | |
| Erstellt von: Breidenbach | Erstellungsdatum: 25/08/2017 | | Maßstab: 1:1 | |
| Teilbeschreibung: Kurze Hydraulikspindel/ Short hydraulic spindle | | | Wärmebehandlung / Härte: vergüteter Stahl/ tempered steel | |
| | | | Oberflächenbehandlung: | |
| Artikelnummer / ZNR.: 802 | Dokumentversion: - | Schutzvermerk ISO 16016 beachten | | |