



Product name

Hydraulic wheel puller for commercial vehicles and low-floor buses



Safe and fast disassembly of the hub on commercial vehicles and buses.

Art. No. Y-60-100

Series Y-60-100

EAN 4021176356780



| | Technical attribute | Metric | Imperial |
|---|---------------------|---|---|
|  | Thread | M16; M18; M20 | M16; M18; M20 |
| für for | Application | ZF A, B und C-Achsen (Typ AV132)RL 75 E, RL 75 EC ; ZF A, B and C-Axes (type AV132)RL 75 E, RL 75 EC | ZF A, B und C-Achsen (Typ AV132)RL 75 E, RL 75 EC ; ZF A, B and C-Axes (type AV132)RL 75 E, RL 75 EC |
| max. | Maximum load | 30 t | 33 US t |
| max. | Maximum pressure | 617 bar | 617 bar |
|  | Weight | 37 kg | |



has to be accomplished with



Hydraulic hand pump

YHP-321

Technologies



HYDRAULIC

Pullers with hydraulic function.



Spare part

| Art. No. | Product name |
|-----------------|----------------------|
| YRH-302 | Hydraulic hollow ram |
| Y318-10 | Crank |
| Y318-12 | Mechanical screw |

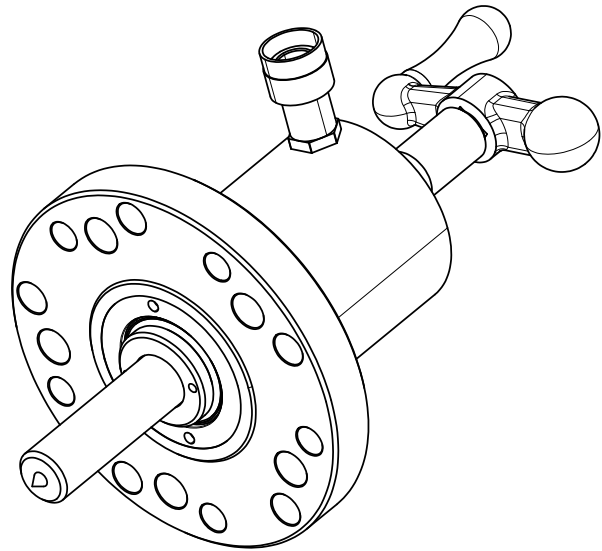
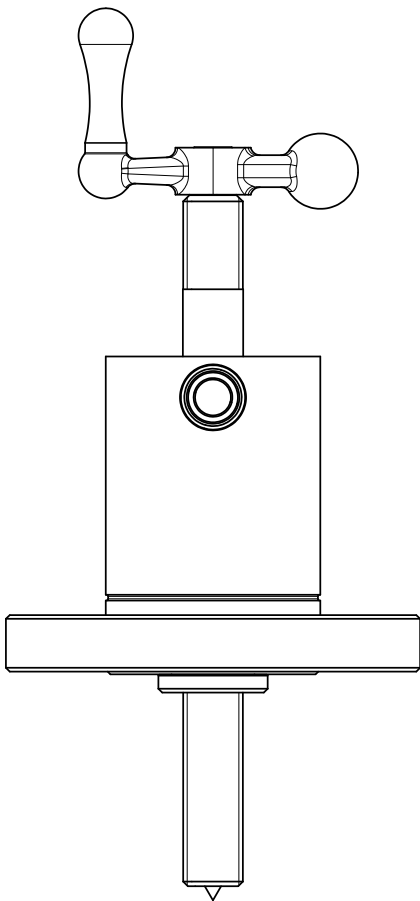
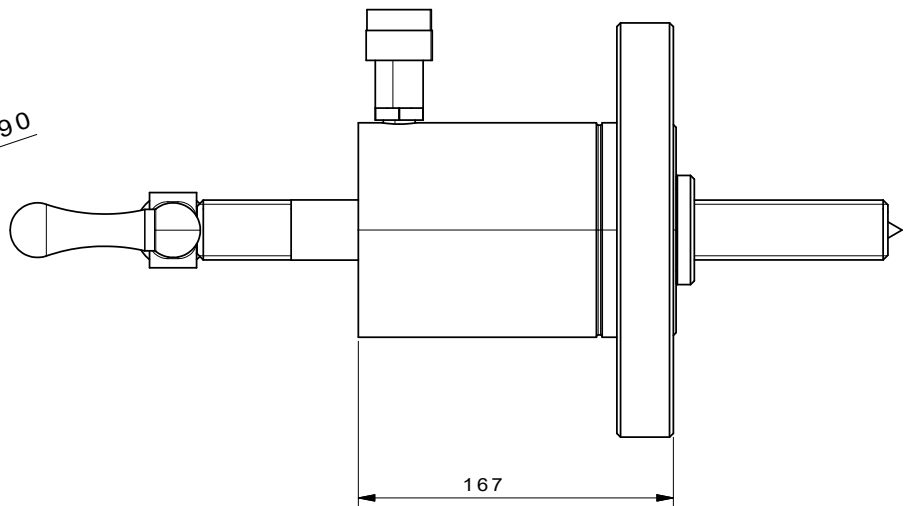
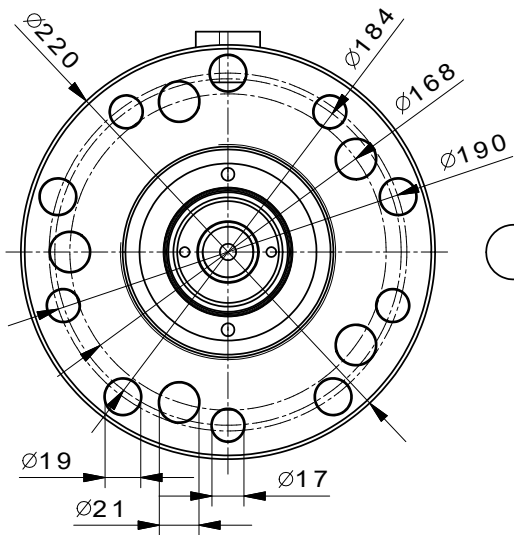

| | | |
|--|--|--|
|  Kleinbongartz & Kaiser oHG Werkzeugfabrik Hilden - Germany | Dokumentname: Y-60-100_Hydraulisches Abziehwerkzeug | Toleranz: DIN ISO 2768-m |
| | Dokumentbeschreibung: Baugruppe | Material: Vergütungsstahl/ heat treatable steel |
| Erstellt von: Breidenbach | Erstellungsdatum: 24/01/2017 | Maßstab: 1:2 |
| Teilbeschreibung: Hydraulisches Radnabenabziehwerkzeug/ Hydraulic wheel puller for low-floor bus: MB Citaro, MAN, Neoplan | | Wärmebehandlung / Härte: vergüteter Stahl/ tempered steel Oberflächenbehandlung: |
| Artikelnummer / ZNR.: Y-60-100 | Dokumentversion: - | Schutzvermerk ISO 16016 beachten |